



ThermoSpas®

Fitness Series

Owner's Manual

SaFety, Maintenance, and Technical InFOrmation

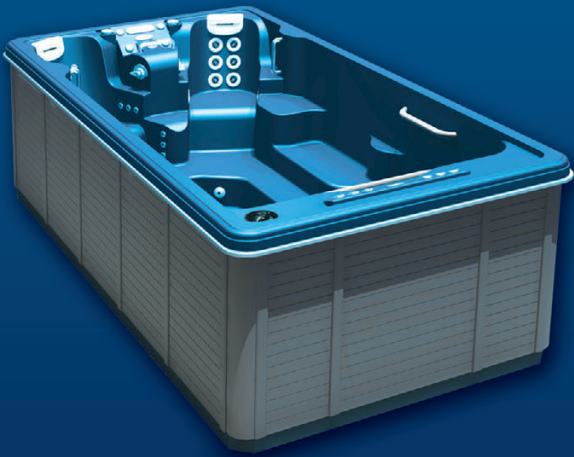

Welcome to ThermoSpas



Welcome To ThermoSpas

Congratulations! You are now the official owner of the finest spa built. All of us at ThermoSpas are looking forward to enjoying a relationship with you that will last for many years to come.

As you get to know your spa, you will quickly discover why ThermoSpas is the fastest growing spa manufacturer in the country. You have made the right decision in choosing ThermoSpas. We're betting our reputation on it. A reputation built on the foundation of our many strengths:

Our Credentials

ThermoSpas has been manufacturing spas since 1983. We strive to stay on the cutting edge of spa design and maintenance technology. We are constantly looking for ways to bring our customers the latest features and products designed to enhance the enjoyment and therapeutic value of our spas. We are a member of the prestigious Association of Pool and Spa Professionals (APSP). One of the APSP's primary goals is "To contribute to the health, safety, and welfare of the public in the installation, maintenance, and operation of swimming pools, spas, and hot tubs." Our best credentials come from thousands of satisfied ThermoSpas owners who write and call us every day to tell us how happy they are with their spas and what a positive difference they have made in their lives.

Our Quality

ThermoSpas' emphasis on quality will become crystal clear with each passing day you own your spa. We make our spas from only the highest quality materials, inside and out. ThermoSpas is the only manufacturer that provides you with a written report signed by two inspection teams. Your spa was tested not once, but twice in hot water to meet our quality assurance standards.

Our Customer Service

Our Customer Care Department is staffed by trained representatives who really care about helping you. They are knowledgeable in every facet of spa maintenance. And they are available to answer your call Monday - Friday 9:00 am - 8:00 pm and Saturday 9:00 am - 3:00 pm, Eastern Time. The Technical Service Department is open Monday - Friday 7:00 am - 7:00 pm and Saturday 8:00 am - 1:00 pm, Eastern Time to answer any of your technical questions or needs.

Your Responsibility To Your Spa

Now that we've told you about our priorities in providing you with an exceptional product and on-going support, we urge you to read through this manual completely. This manual, along with the information previously supplied in the Welcome Kit will familiarize you with the simple operation and maintenance of your spa (which will become second nature to you in no time). Most importantly, it will help you keep your spa running smoothly and in tip-top condition for many years to come.

Have Fun and Enjoy!

Safety Requirements

Proper Use & Installation	2
Chemical Safety Requirements	5

Components

Spa Diagram	6
Topside Control Panels	7
Pumps	8
Jets	9
Valves	11
Lights	12

Installing Your Spa

Preparing For Installation	13
Electrical Set Up	14
Spa Start Up	16
Spas With ThermoOzone	21

Water Maintenance

On-Going Spa Maintenance	22
Chlorine	23
3-Part Activated Bromine	24
Bromine Tabs	25

Two-Part Bromide	26
ThermoClear	27
Water Chemistry	28

Spa Maintenance

Basic Spa Maintenance	29
Changing/Cleaning Filters	30
Drain & Refill	31
Cleaning the Cover	32
Flushing Lines	32
Shell Surface Cleaning	33
Closing Your Spa (Winterizing)	34

Troubleshooting

Water Chemistry	35
Control Panel Operation	36
Common Diagnostic Messages	39
Mechanical Systems	40

Frequently Asked Questions

Glossary	44
----------	----

Throughout this manual you will see the term “spa” and “hot tub”. These terms are generic and used interchangeably to mean “spa”, “hot tub”, “swim spas”, “Spa Trainer”, “Spa Swimmer” and “Aquadisor”.

How To Contact Us

Office	800.876.0158
Fax	203.265.7133
Customer Care Department	800.876.0158, option 2,2
Technical Service Department	800.876.0158, option 2,3
Address	ThermoSpas • 155 East Street Wallingford, CT • 06492
Website	www.thermospas.com

Read & Follow These Important Instructions

When using the electrical equipment, basic safety precautions should always be followed.

A green colored terminal marked G, GR, Ground, Grounding or the Symbol  is located inside the supply terminal box or compartment. To reduce the risk of electric shock, this terminal must be connected to the grounding means provided in the electric supply service panel with a continuous copper wire equivalent in size to the circuit conductors supplying this equipment.

At least two lugs marked "BONDING LUGS" are provided on the external service or on the inside of the supply terminal box or compartment. To reduce the risk of electric shock, connect the local common bonding grid in the area of the hot tub or spa to these terminals with an insulated or bare copper conductor not smaller than No. 6 AWG.

All field-installed metal components such as rails, ladders, drains, or other similar hardware within three meters of the spa or hot tub shall be bonded to the equipment grounding bus with copper conductors not smaller than No. 6 AWG.

Save These Instructions

Proper Use & Installation

ThermoSpas has made every effort to provide you with a safe and reliable product. The detailed instructions provided previous to, and with the receipt of, your spa will explain how to safely install, operate and maintain your ThermoSpa. Safety in using a spa ultimately lies with you the customer. There is no substitute for the use of good judgment and common sense when it comes to safety in and around your spa.



WARNING

Safety In and Around Your Spa

- **Supervision** is the key factor in the safe use of your spa. Children must never be allowed to use the spa unless adult supervision is present at all times.
- Your spa must be **secured** against unauthorized use. Always completely cover your spa and lock the cover in place when not in use to reduce the risk of a child entering without adult supervision.
- ThermoSpas recommends you **do not drink alcoholic** beverages or take drugs of any kind (including prescription & over-the-counter) before using your spa. These substances may affect a person's ability to withstand elevated water temperatures and may produce dangerous effects in heart rate, blood pressure, and circulation. They may also lead to unconsciousness and the possibility of drowning.
- The wet surface of a spa is **slippery**. Use care when entering or exiting. Never allow running, jumping, pushing, or roughhousing inside or around the spa.
- Keep body parts and clothing a minimum of 12" away from the filter skimmer at all times. Hair longer than shoulder length should be secured close to the head or covered with a bathing cap.
- There are suction fittings located along the sides of the foot well of your spa. Do not remove the covers over the suction fittings because they are a safety device. The covers minimize the possibility of hair or body parts getting caught in them.
- Water temperatures between 100°F and 104°F are considered safe for healthy adults. Temperatures higher than 104°F for an extended period of time may raise the body temperature beyond safe limits and impair the body's ability to regulate its internal temperature.
- It is best to limit initial use of your spa to 10-15 minutes because high body temperatures affect each person differently. We recommend consulting with your physician about your comfort & safety before using the spa.
- Activating the spa without sufficient water can damage the circulation pump and heater, and may cause a fire.

- Do not locate lighting fixtures directly above, or within 5 Ft. of the spa. If they are located within 10 Ft. of the spa, they must be on a circuit protected by a Ground Fault Circuit Interrupter (GFCI).
- Before attempting electrical hook-up, please read and follow safety instructions on pages 14 - 15.

WARNING

Children should not use spas or hot tubs without adult supervision.

AVERTISSEMENT

Ne pas laisser les enfants utiliser une cuve de relaxation sans surveillance.

WARNING

Do not use spas or hot tubs unless all suction guards are installed to prevent body and hair entrapment.

AVERTISSEMENT

Pour éviter que les cheveux ou une partie du corps puissent être aspirés, ne pas utiliser une cuve de relaxation si les grilles de prise d'aspiration ne sont pas toutes en place

WARNING

People using medications and/or having an adverse medical history should consult a physician before using a spa or hot tub.

AVERTISSEMENT

Les personnes qui prennent des médicaments ou ont des problèmes de santé devraient consulter un médecin avant d'utiliser une cuve de relaxation

WARNING

People with infectious diseases should not use a spa or hot tub.

AVERTISSEMENT

Les personnes atteintes de maladies infectieuses ne devraient pas utiliser une cuve de relaxation.

WARNING

To avoid injury exercise care when entering or exiting the spa or hot tub.

AVERTISSEMENT

Pour éviter des blessures, user de prudence en entrant dans une cuve de relaxation et sortant.

WARNING

Do not use drugs or alcohol before or during the use of a spa or hot tub to avoid unconsciousness and possible drowning.

AVERTISSEMENT

Pour éviter l'évanouissement et la noyade éventuelle, ne prendre ni drogue ni alcool avant d'utiliser une cuve de relaxation ni quand on s'y trouve.

WARNING

Pregnant or possibly pregnant women should consult a physician before using a spa or hot tub.

AVERTISSEMENT

Les femmes enceintes, que leur grossesse soit confirmée ou non, devraient consulter un médecin avant d'utiliser une cuve de relaxation

WARNING

Water temperature in excess of 104°F (38°C) may be injurious to your health.

AVERTISSEMENT

Il peut être dangereux pour la santé de se plonger dans de l'eau à plus de 38°C.

WARNING

Before entering the spa or hot tub measure the water temperature with an accurate thermometer.

AVERTISSEMENT

Avant d'utiliser une cuve de relaxation mesurer la température de l'eau à l'aide d'un thermomètre précis.

WARNING

Do not use a spa or hot tub immediately following strenuous exercise.

AVERTISSEMENT

Ne pas utiliser une cuve de relaxation immédiatement après un exercice fatigant

WARNING

Prolonged immersion in a spa or hot tub may be injurious to your health.

AVERTISSEMENT

L'utilisation prolongée d'une cuve de relaxation peut être dangereuse pour la santé.



Do not permit electric appliances (such as a light, telephone, radio, or television) within 5 Ft (1.5 m) of this spa or hot tub.



Ne pas placer d'appareil électrique (lumière, téléphone, radio, téléviseur, etc) à moins de 1.5 m de cette cuve de relaxation



Maintain water chemistry in accordance with manufacturer's instruction.



La teneur de l'eau en matières dissoutes doit être conforme aux directives du fabricant.



Failure to provide a dedicated circuit can cause equipment damage and invalidate your warranty.



The continuous service GROUND wire is located in the line cord supplied. Do not modify this cord in any way. Tampering with the GROUND wire or using an adapter which would render the built-in grounding device ineffective would cause electric shock. Such modification nullifies your warranty.



As a spa owner, it is important for you to know that you may be legally responsible for the safety of all persons who use it. Be sure to update your insurance policy to include ownership of your spa.



Safety For Pregnant Women, Infants, and People with Health Conditions

- Elderly people, pregnant or possibly pregnant woman, obese individuals, or anyone with a history of heart disease, low or high blood pressure, circulatory problems, or diabetes must consult with a physician before using a spa.
- Infants must never be in a spa with a temperature of over 100°F (38°C).
- Lower water temperatures are recommended for extended use exceeding 10-15 minutes for young children, pregnant women, women who may be pregnant. High water temperature can cause fetal damage during the first few months of pregnancy.



Be Aware of the Risk of Fatal Hyperthermia

The use of alcohol, drugs, or medications can greatly increase the risk of fatal hyperthermia. Hyperthermia occurs when the internal body temperature reaches a level several degrees above normal body temperature (98.6°F). The symptoms of hyperthermia include dizziness, fainting, drowsiness, lethargy, and an increase in the body's internal temperature.

The effects of hyperthermia include:

- Failure to perceive heat
- Physical inability to exit the spa
- Unconsciousness and danger of drowning
- Failure to recognize impending hazard
- Failure to recognize the need to exit the spa
- Fetal damage in pregnant women



For All Indoor Hot Tub Installations

- All indoor hot tubs must be installed in rooms with proper ventilation.
- Keep the hot tub completely covered and locked when the spa is not in use.
- **IMPORTANT:** It is the owner's responsibility to keep water properly sanitized at all times.
- Install indoor hot tubs on non-porous flooring with adequate drainage.*

It is critical to complete all of these above steps in order to prevent bacteria-ridden water from becoming bacteria-ridden vapor in the hot tub room. If the room is poorly ventilated, this vapor can fill the enclosed air space creating a health hazard. The breathing in of this vapor may cause lung infections.

* ThermoSpas, Inc. is not responsible for any damage to flooring, carpeting, ceiling, furniture, personal items or walls due to malfunctioning or leaking of hot tub.

**WARNING**

Spa and Water Maintenance

Because the environment and individual circumstances surrounding a spa's use and operation may vary, this Owners' Manual is intended to provide certain guidelines for the safe and enjoyable use, operation and maintenance of your spa. The spa's components and water chemistry are the sole responsibility of the owner. Neither ThermoSpas, Inc., its representatives or distributors shall be liable for any injury, loss or damage of any kind or nature resulting from deficient or improper maintenance of the spa, its components or water chemistry.

Chemical Safety Requirements

**WARNING**

Improper use of chemicals can be dangerous and possibly damage your spa, which would not be covered by your warranty. It is extremely important to take the necessary precautions when using these chemicals.

**WARNING**

You should avoid using any biguanide or copper-based algaecides with your spa. Use of these products or any other products not recommended by ThermoSpas may void your warranty.

Proper Handling of Chemicals

1. Keep all chemicals out of reach of children.
2. Always keep lids on chemicals when not in use and store them in a cool, dry location away from direct sunlight.
3. Do not store chemicals within the interior of the spa's cabinet.
4. Do not interchange caps or measuring scoops for different types of chemicals.
5. Do not smoke around chemicals. Some can emit fumes that can be highly flammable.
6. In case of contact or if a chemical is swallowed, call a doctor or local Poison Control Center. If a doctor is required, bring the chemical container with you so the doctor can determine the appropriate treatment.
7. If you have questions regarding chemical care call Customer Care. The staff is there to help you with guidelines and best practices.
8. MSDS sheets are available upon request.

Proper Use of Chemicals

1. Always make certain the filtration pump (pump 1) or circulation pump is turned on when adding chemicals.
2. Add only one chemical at a time to the water.
3. Never use swimming pool chemicals in your spa, they may void your warranty.
4. After adding any chemical, wait at least 10 minutes before adding the next chemical.
5. Never mix chemicals or chemical solutions directly with each other.
6. Always add chemicals to water when mixing them. Never add water to chemicals.

Spas with Audio/Video Components or Refrigerator

**WARNING**

Risk of Electric Shock - Do not leave compartment door open.

**WARNING**

Risk of Electric Shock - Replace components with only identical components.

**WARNING**

Prevent Electrocution - Do not connect any auxiliary components to the system.

Important Reminders

- ✓ Make certain to sanitize your spa water and maintain correct water chemistry.
- ✓ Keep the spa cover on and locked at all times whenever you are not using it.
- ✓ Regularly clean your filter cartridge(s) using ThermoSpas' Filter Cleaner.
- ✓ Follow the recommended maintenance procedures and schedules.

Spa Diagram

The illustrations below show a typical spa with multiple jet styles, an ozone system, and an independent circulation/filtration pump system. IF your spa was not ordered with any of these features, the system components will not be found in your spa. Refer to special operating instructions specific to your spa for more details. These illustrations are designed to help you identify key components. Use the legend to locate a particular component's page number to see more details.

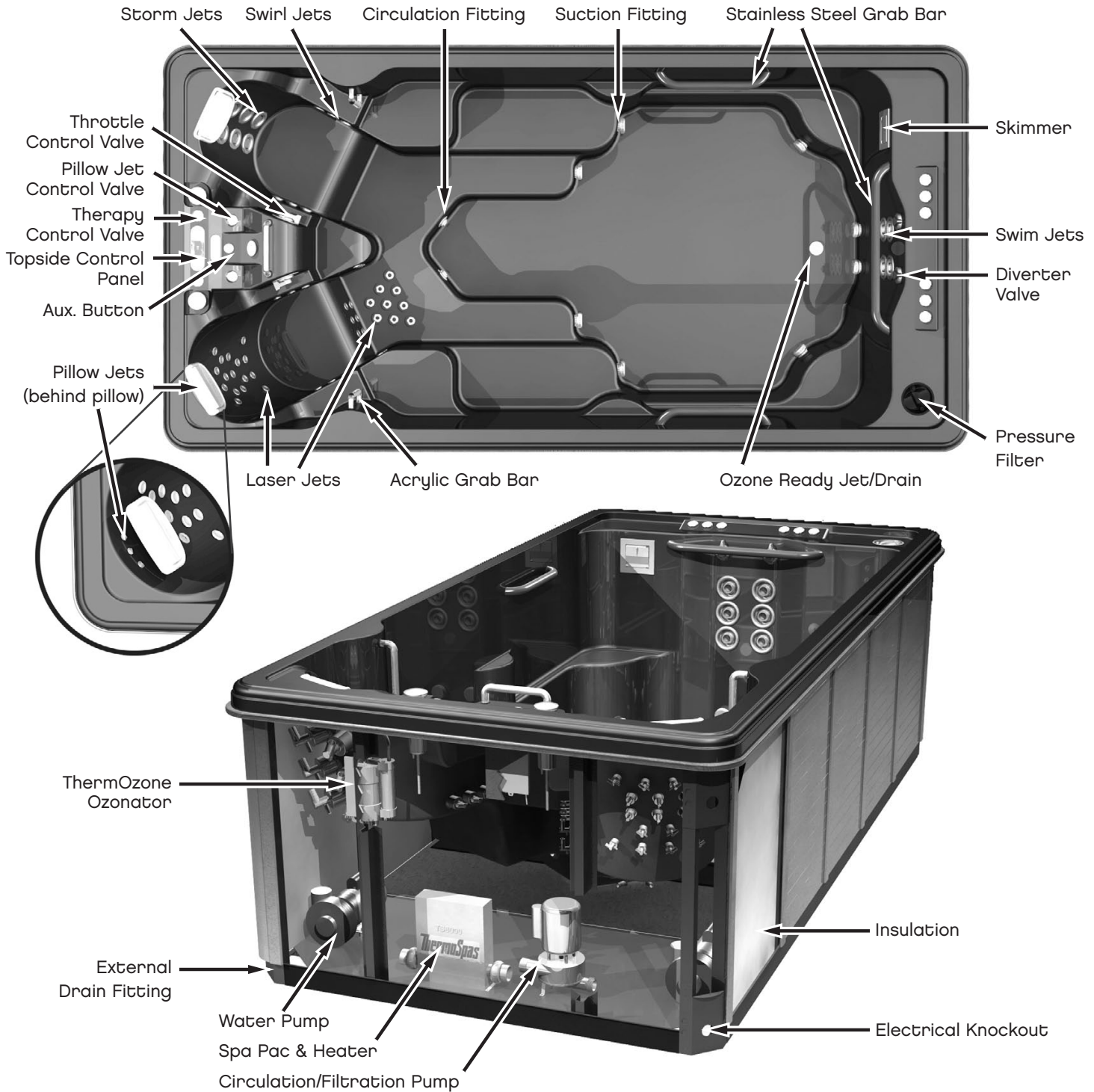

Part	Page #	Part	Page #	Part	Page #
Storm Jet	10	Throttle Control Valve	11	Water Pump	8
Diverter Valve	11	Ozone Ready Jet	21	ThermOzone Ozonator	21
Therapy Control Valve	11	Laser Jet	9	Spa Pac & Heater	7
Swim Jet	10	Topside Control Panel	7, 36-38	Air Pump (Blower)	8
Swirl Jet	9	Grab Bar	12	Circulation/Filtration Pump	8

Topside Control Panels

For the control panel specific to your spa refer to the Special Operating Instructions (SOI) that came with your spa or log onto www.thermospas.com and click on "Customer Center". Buttons A, B, C, D may vary depending on your specific spa model and any custom options.



Main Control - TS700



Swim Control



Wave Control

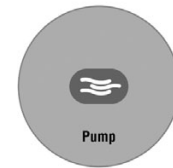

Aux Button



Blower Button:
Turns blower on or off.



Light Button:
Turns light on/off. Activates LED's where applicable. Some models have Low, Medium, High settings.



Mode Button:
Choose between Standard, Sleep, or Economy modes. See the Special Operating Instructions that came with your spa for description of modes.



Jets/Pump Button:
Turns Jets/Pumps on or off. On some models the pump may be 2 speeds (low/high). See the Special Operating Instructions that came with your spa for more details.



F1, F2

Lights indicate Filter cycles

PL

Light on indicates homeowner locked panel

TL

Light on indicates homeowner locked temperature



Time:
Displays time of day. Refer to Special Operating Instructions to pre-set.



Warm Button:
Used to increase hot tub temperature setting.



Cool Button:
Used to decrease hot tub temperature setting.



Temp Button:
Adjusts the hot tub temperature setting from the Swim Control Panel. Refer to the Special Operating Instructions that came with your spa.

Spa Pac & Heater (Electronic Center of Spa)

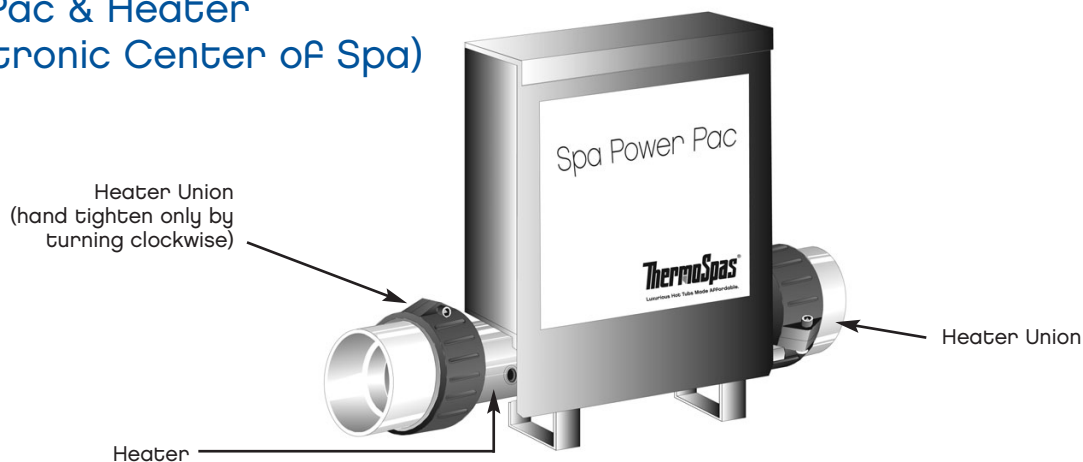

Pumps

Water Pump

NOTE: On some water pumps, pipes heading to water jets may be located on the top of the pump. However, the configuration of the hose, "T" valve, remains the same.

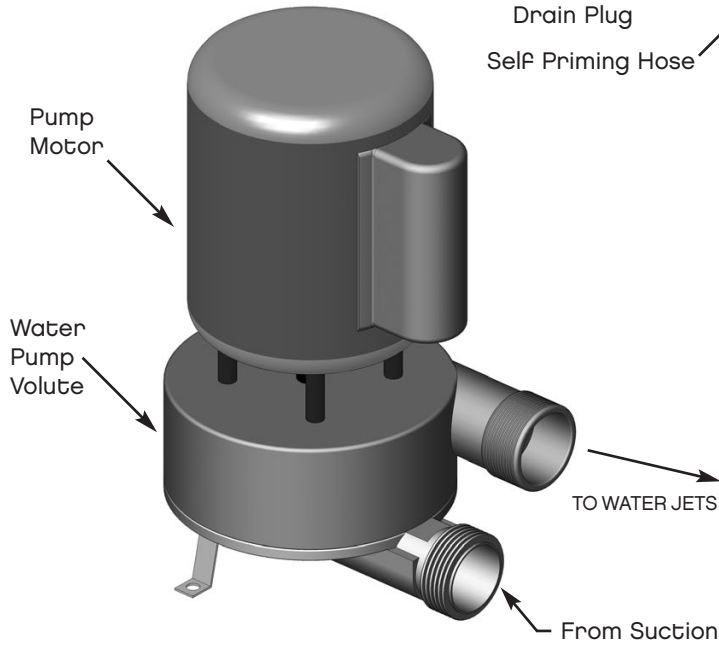
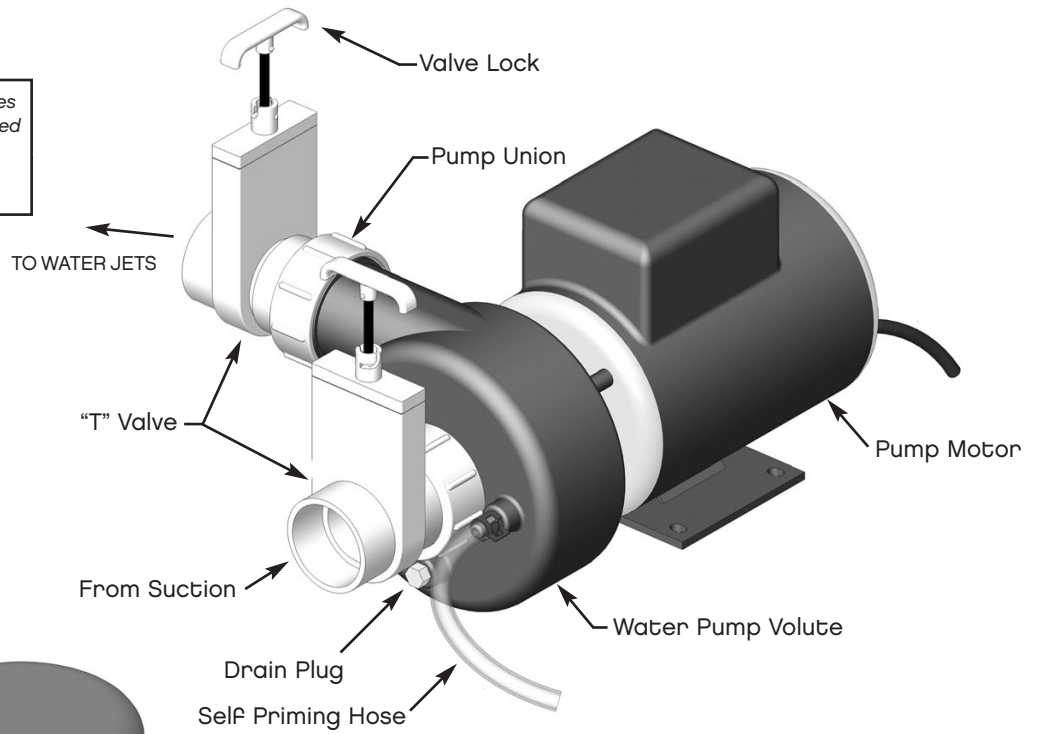

Circulation/ Filtration Pump

Spas are equipped with a circulation pump for continuous filtration. Please refer to the Special Operating Instructions included with your spa.

Air Pump (Blower)

Some Spas are equipped with an air blower for the Bubbling System. (Not available on all models.)

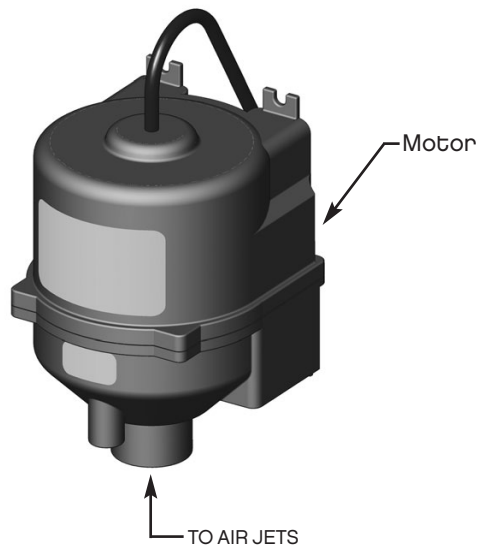

Jets

Jets shown in illustrations below have standard housings. Stainless steel jet housings (not shown) are available for some models. Your model hot tub may not come equipped with all jets shown.

Pulsating Jet & Laser Jet

The Laser Jet and Pulsating Jet are interchangeable and allow you to customize the feel of your water therapy. To remove the Jet from the Jet Body, turn the Jet counter-clockwise until you feel resistance. Continue turning counter-clockwise and pull until the Jet pops out. When inserting the Jet into a Jet Body, you must align the On/OFF Stop with the middle of the On/OFF Stop Track to insure proper seating of the Jet. Simply push the Jet into the Jet Body until you hear it snap into place.

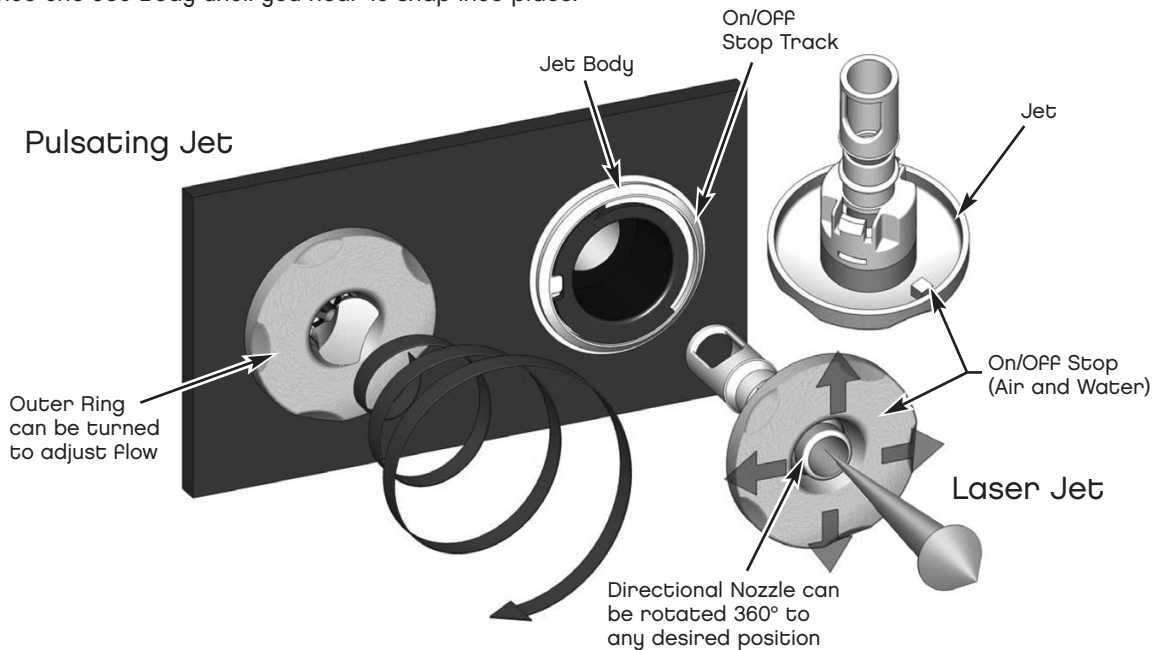

Swirl Jet & Therapy Jet

The Swirl Jet and Therapy Jet are interchangeable and allow you to customize the feel of your water therapy. To remove the Jet from the Jet Body, turn the Jet counter-clockwise until you feel resistance. Continue turning counter-clockwise and pull until the Jet pops out. When inserting the Jet into the Jet Body, you must align the On/OFF Stop with the middle of the On/OFF Stop Track to insure proper seating of the Jet. Simply push the Jet into the Jet Body until you hear it snap into place.

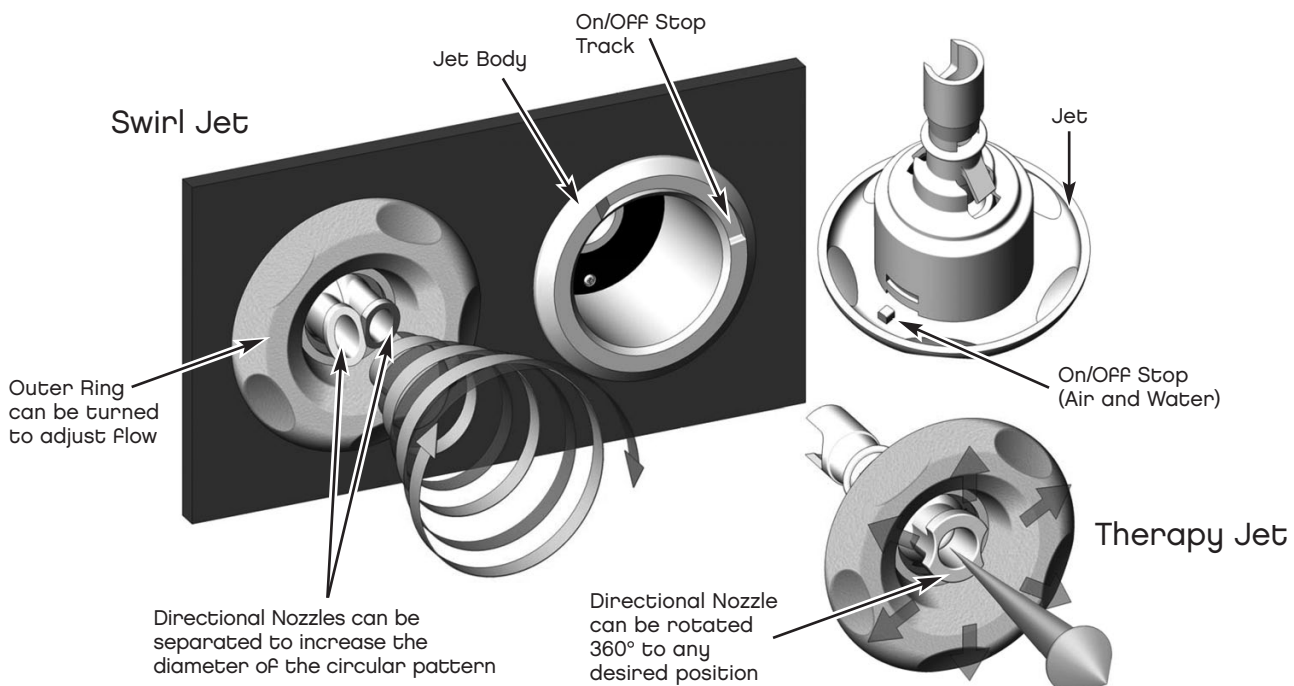

Swim Jet

This oversized, powerful jet is designed specifically to move water at the flow rates required to provide a quality workout. If equipped with an optional nozzle the jets may be adjusted to direct the water flow according to swimmer's preferences.

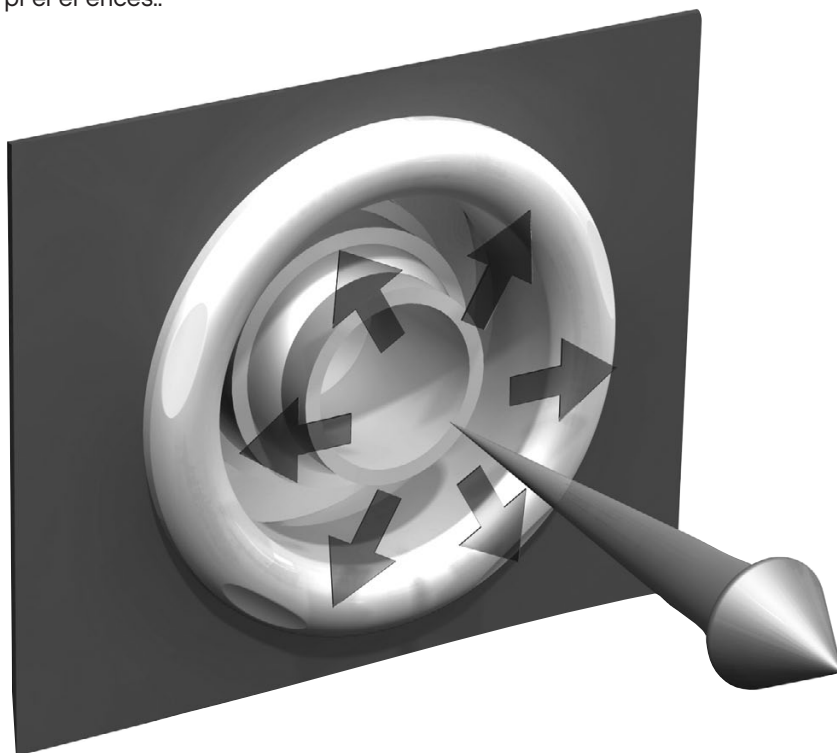

Storm Jet

A large round jet that is particularly good for those with special therapy needs because they create a powerful current. These jets provide a swirling, pulsating water stream for hydrotherapy. They may be turned on or off individually as the bather desires.

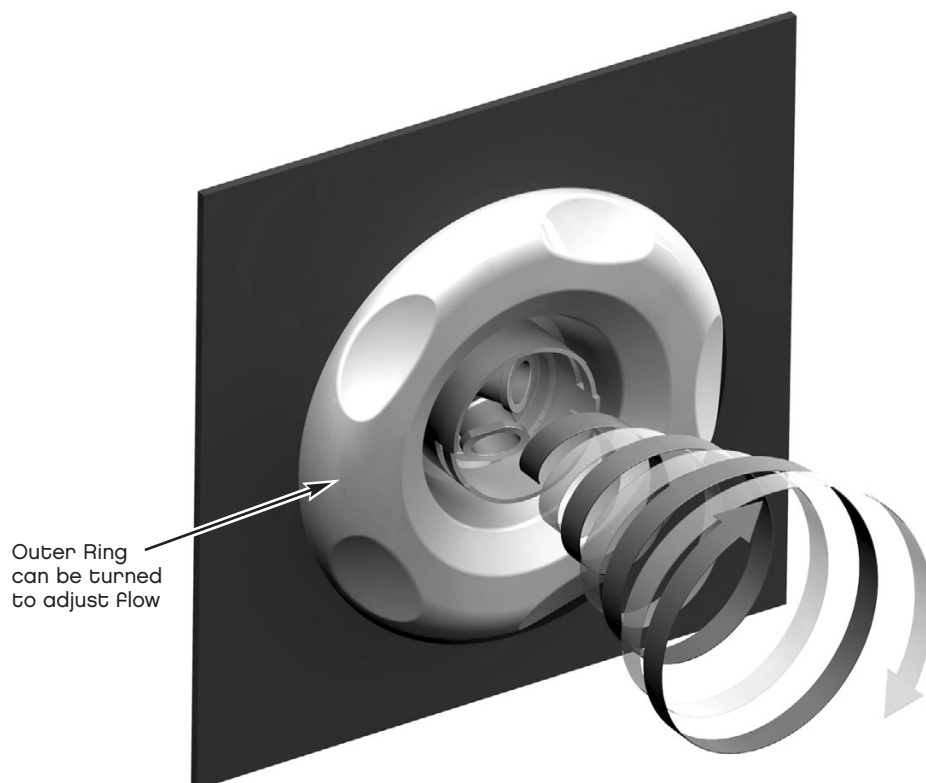

Valves (Optional on some spa models)



Blower Control Valve

Controls the intensity of the air blower on spas equipped with a bubbling system.

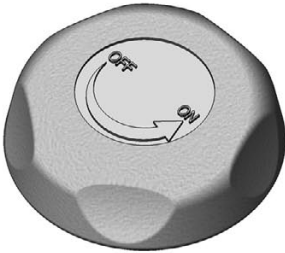

Pillow Jet Control Valve

Controls the water intensity flow to the pillow jets. Turn the valve clockwise to lessen the intensity; counter-clockwise to increase the intensity.

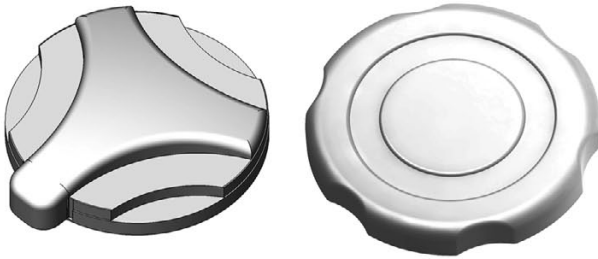

Therapy Control Valve

Controls the water to air ratio to vary the intensity of the jet.



Diverter Valve

Rotate valve to divert flow to specific sections of the hot tub. See special operating instructions for more details.



Throttle Control Valve

The patented Throttle Control Valve controls the jet intensity of an entire seat without affecting others areas.

Lights

Grab Bar Light Assembly (Optional on some spa models)

The Bulb Socket is attached to the Bulb housing by aligning the (2) Bulb Socket Twist Lock Features with the (2) Twist Lock Paths on the Bulb Housing. Insert the Bulb Socket until it stops at the rear of the Bulb Housing, then turn until the Bulb Socket Twist Lock snaps into place. Reverse this procedure to remove the Bulb Socket.

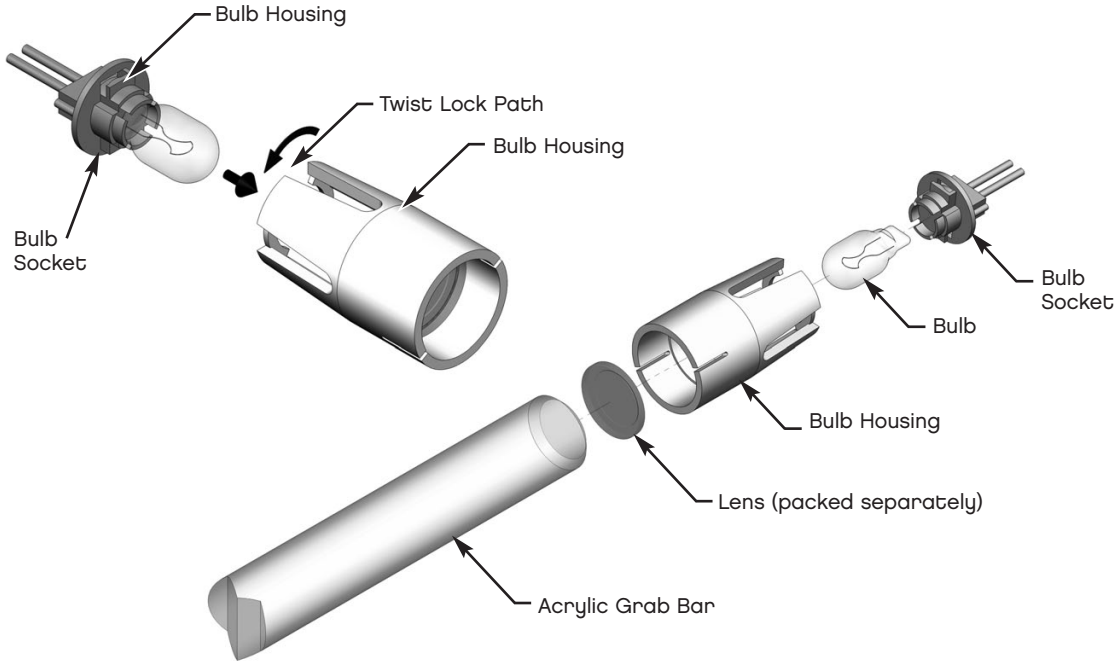

Spa Light Assembly

The Bulb Socket is attached to the reflector by aligning the Bulb Socket Twist Lock Features with the Twist Lock Paths on the Reflector. Insert the Bulb Socket until it stops at the rear of the Reflector, then turn until the Bulb Socket Twist Lock snaps into place. Reverse this procedure to remove the Bulb Socket.

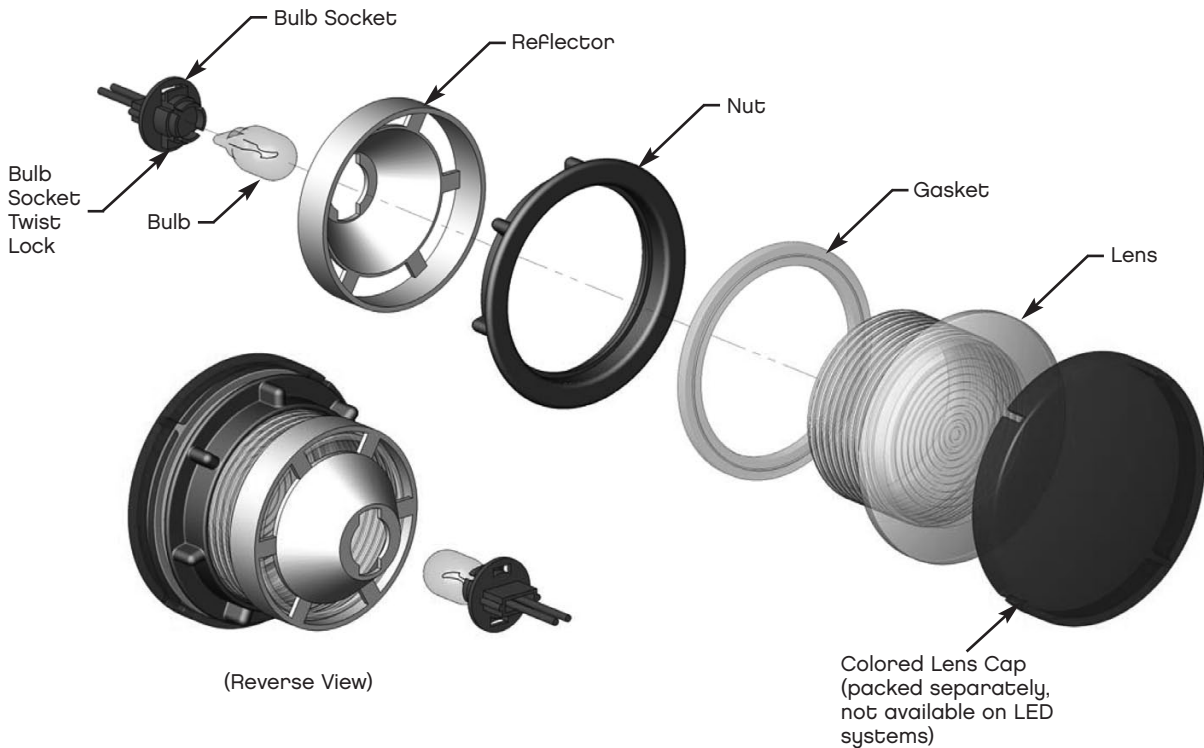

On spas equipped with LED lighting systems, the light assemblies are non-user-serviceable parts. Please call the service department if you need assistance.

Preparing for Installation

Site preparation, alterations to homeowner's property and permits (if any) are the sole responsibility of the owner. ThermoSpas are not intended for commercial applications.

Your Site

Wherever you place your spa leave a **minimum of 18" clearance on all sides of the spa for service**. In the event the spa requires servicing, failure to leave proper access may require the owner to drain the spa and move it prior to the service call. **Providing service access is the responsibility of the owner**. It's recommended that extra space be provided in the spa front side (typically the side below the control panel). If you have a problem locating the panel for your spa pac, please refer to the Engineering Drawings at our Customer Center at www.thermospas.com.



Portable spas must be placed in a location with adequate ventilation and drainage to ensure that water does not accumulate under or around the spa and to remove water vapor.



Do not rest your spa directly on top of a power line. Electrical shock or power failure may result. The power line to the spa should be routed to come up through the bottom of the spa cabinet or through the side wall by drilling a mouse hole (see page 15).

Outdoor Location

Your spa must be located above ground on a level, well-supported, continuous surface. ThermoSpas, Inc. recommends a concrete pad. Do not locate it on gravel, dirt, sand, or grass because these are unstable surfaces and may shift or compress over time. Shifting can cause the spa to warp, therefore voiding the warranty.

Indoor Location

If your spa is going indoors, do not place it directly on carpeting or a hardwood floor due to possible splash out from the tub. ThermoSpas recommends that spas installed indoors be placed on a **non-porous surface with a drain**. Some units contain as much as 1,200 gallons of water. Water damage to the homeowner's property from splashing or leaks are at the homeowner's risk. ThermoSpas does not provide any service or warranty coverage for water damage. Please check your homeowner's insurance policy to see how you are covered.

Level Your Spa

Whether outdoors or indoors, your spa must sit on a solid, level surface. If the surface is not level, the uneven weight distribution may cause major problems. Cabinet panels can become difficult to remove over time, and the constant pressure may eventually cause the spa shell to warp, crack and separate from the cabinet. This damage is not covered under your warranty.

To determine if the spa is level, place it in the desired location and check it with a level before you fill it to save time. If the spa is already filled and is not level, you will see an uneven water line around the spa's inside perimeter. If this happens, we recommend you empty the spa immediately and have a licensed contractor level the surface it sits on.

Weight Considerations



We do not recommend using shims to level the spa because if the entire footwell area and perimeter of the cabinet are not properly supported, the spa will warp and the warranty will be void.



If your spa is sitting on any elevated surface, it should meet current state and local building codes. It must be able to support the weight of a spa filled with water and people (which could be as much as 14,000 lbs.). The Spa Swimmer/Spa Trainer and larger spas may exert floor loading up to 160 lbs./sq ft. Check with your builder or town official to determine the loading capacity of spa site.

The Safe Electrical Hook-up of Your Spa

Before beginning the wiring process turn off the circuit breaker so that no power is connected to the controller. ThermoSpas recommends all spa wiring to be done by a licensed electrician. Improper wiring may void your warranty. Incorrect or incomplete wiring will very likely create a dangerous hazard. Performing a conversion or any other modification to the original hardware or installation configuration mandates that the owner assumes full responsibility for assuring that the resulting system complies with all applicable national, state, and local wiring codes and ordinances for the location of the unit. Be aware that there are major differences in wiring codes if this unit is to be installed at any location other than a private residence.

- The electrical installation of your spa should be done by a qualified electrician in accordance with the National Electrical Code (NEC), and all local codes effective at the time of installation.
- Your spa must be installed on a dedicated electrical circuit. No other appliances or electrical equipment may be used on this circuit.



If your spa is not installed in accordance with the NEC, it may create a dangerous safety hazard. Improper electrical installation may also damage the inner workings of a spa and void your warranty.



If your electrician is not absolutely sure how to correctly connect your system, call the ThermoSpas Technical Service Department at 800.876.0158, option 2. Mistakes may be costly and will invalidate your equipment warranty.

Electrical Set Up

Before beginning the wiring process turn off the circuit breaker so that no power is connected to the controller. ThermoSpas recommends all spa wiring to be done by a licensed electrician. Improper wiring may void your warranty.

Electrical Service Requirements:

Before wiring for a spa, one of the first considerations is whether or not your main service or subpanel feeding your spa has the capacity to provide sufficient power to your spa. A licensed electrician will be able to perform a load calculation to determine this.

The electrical requirements for your hot tub are found on the Electrical Guide Sheet contained in the Welcome Kit (or at www.thermospas.com) for your specific model. **It is very important to review your electrical requirements before starting installation.**



Wiring to your spa must be COPPER ONLY! Note that the wiring from a main panel to a subpanel for the spa may be aluminum provided it is sized properly and the subpanel is rated for aluminum or copper (AL/CU).

In all spa installations, refer to the The Electrical Guide sheet contained in the Welcome Kit or at www.thermospas.com.

The length of the wiring from the panel or feed to your spa also has to be determined. If the total run exceeds 75 feet, the wire size must be increased by one wire size between the main panel and the disconnect to adjust for the corresponding voltage drop. Wiring between the disconnect and the spa pac cannot exceed 6 gauge. To make future service work easier we recommend leaving at least 6' of slack in the main electrical wire which may be coiled inside the cabinet.

Ground Fault Circuit Interrupt (GFCI) Requirements: All spa electrical circuits must be GFCI protected on a dedicated circuit.

It is common practice for electrical service for a spa to be supplied by a regular two-pole breaker at the rated amperage at the main panel, and the disconnecting means (NEC Article 100) is usually a **125-amp subpanel with the required GFCI breaker(s) mounted inside**. The GFCI breaker becomes the required disconnecting means. These subpanels sometimes will not have a ground bar included and it must be purchased separately. The ground bar is a small metal bar with holes provided for ground wires and screws to secure the wires to the ground bar. This ground bar is NOT to be bonded or connected to the neutral bar; and the neutral bar must be isolated from any grounding source. The GFCI pigtail in this instance is connected into the neutral bar—not the ground bar.

Suggested Wiring with GFCI Breaker to Subpanel

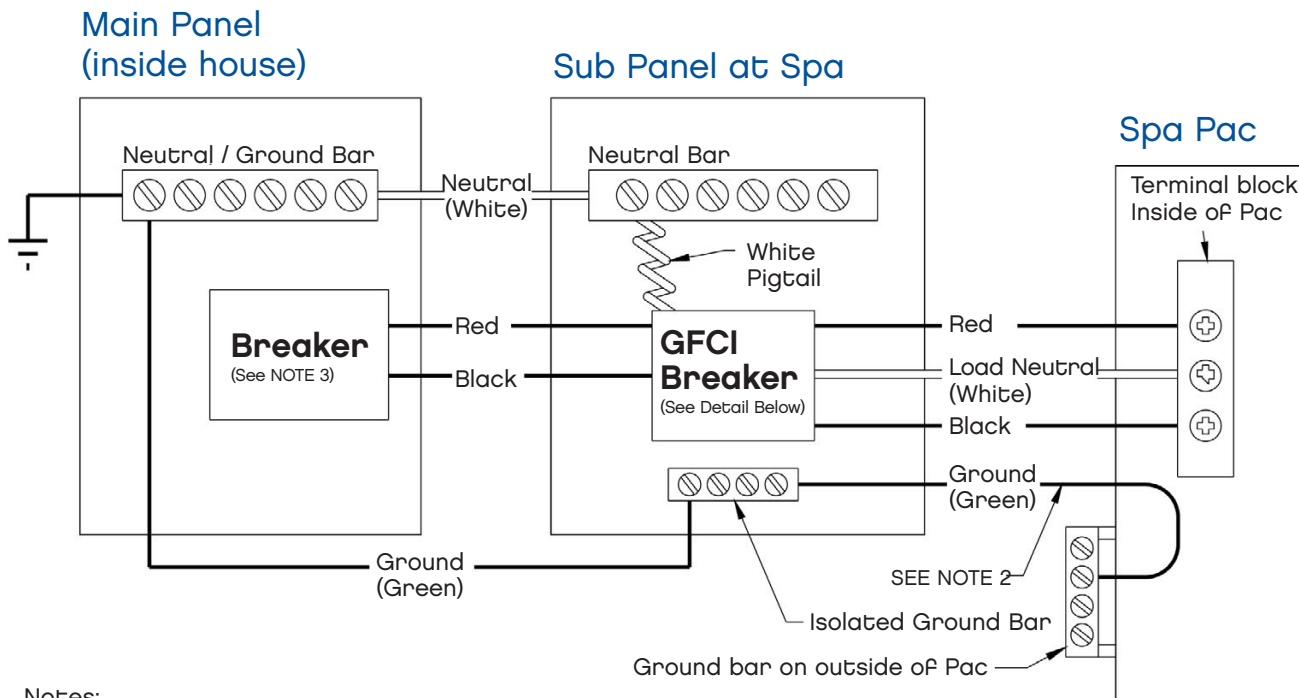

Notes:

1. NEUTRAL & GROUND MUST BE ISOLATED AT THE SUB PANEL.
2. On Balboa TS Series Pacs, ground wire must enter the Pac through strain relief and attach to ground bar on outside of Pac.
3. Positions of electrical connections may vary by breaker manufacturer.
4. For specific breaker and wire size refer to your Electrical Guide

GFCI Breaker Detail

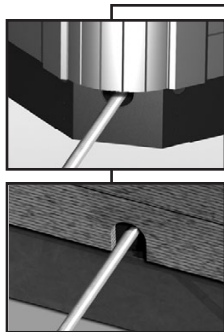
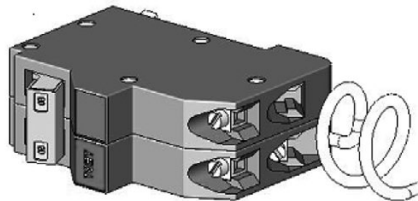

Before routing power to your spa, refer to the Engineering Drawings in your Welcome Kit or at www.thermospas.com for the recommended electrical service.

If you are routing the power through the side of the spa, drill a small mouse hole at the bottom of the cabinet panel closest to the power source. This will allow the panel to be easily removed without disconnecting the power line.



Do not rest your spa directly on top of a power line. Electrical shock or power failure may result. The power line to the spa should be routed to come up through the bottom of the spa cabinet or through the side wall by drilling a mouse hole.

Spa Start Up

Please read through all steps before beginning. This section explains the necessary procedures required to start up your spa. Familiarize yourself with this procedure prior to beginning the process. Use this procedure as a guideline.

- Make sure you have any Special Operating Instructions along with the Welcome Kit and Chemical Starter Kit prior to filling your spa.
- If your water is acidic, hard, or has a high mineral content it is recommended to contact one of our trained Customer Care Representatives prior to filling your spa.
- Failure to follow these start-up instructions for your spa and observe the recommended maintenance time periods may result in pump damage or require draining and refilling the spa.

Overview of Start Up - See instructions below for details on each step.

Total start-up process time will vary from 3-24 hours based on the following variables:

1. Incoming water temp & water pressure (fill rate)
2. Size and type of hot tub
3. Water characteristics (hardness, mineral content)
4. Desired final water temperature
5. Ambient Conditions



1. Inspect & Filling

Once your spa is in its final location and has been electrically connected, it is time to inspect it to ensure it is ready to be filled. **Before you inspect your spa, turn the circuit breaker off.**

- Step 1:** Turn off the circuit breaker and gently remove all packing and crating materials from the spa.
- Step 2:** Remove the front panels/insulation of the spa so you can see the interior.
- Step 3:** Remove filters and the accessory bag located inside the cabinet interior, and the spa chemical starter kit.
- Step 4:** Wipe spa clean with a soft damp sponge. Be careful not to scratch the surface with any particles that may have fallen into the tub.
- Step 5:** Make sure the "T" valves on each water pump are open by pulling them up as far as they will go. *(see pg 8)*
- Step 6:** Check all drain plugs located on each water pump to make certain they are closed. *(see pg 8)*
- Step 7:** Make sure all water pump and heater unions are tight. *(see pg 8)*
- Step 8:** Make sure the external drain fitting is closed.
- Step 9:** Install the filter(s). *(see SOI)*

Step 10: Ensure your water source is safe for hot tub use. Water may contain minerals that may cause stains or deposits. Water with a high mineral count, such as iron or copper, may discolor the water once a sanitizer is added. If you have any doubt, visit www.thermospas.com or call our Customer Care department during our normal business hours.

Step 11: Let the water run out of your garden hose for several minutes before filling the spa. This will flush out stagnant water in the line that may cause bacteria.

Tip: We suggest putting a pre-filter or sock over the end of your hose to act as a strainer and protect the spa shell acrylic from the hose.

Step 12: Begin filling your spa. The actual water level may vary depending on the bather load. When there are no bathers in the spa, the water must be high enough to prevent pump surge and low enough that when the recommended number of bathers are in the tub that the water is not overflowing out of the spa. The recommended water level is half way up the filter area with no bathers. While spa is filling periodically check underneath to be sure unions are tight and not leaking.

Tip: Unions are located on both the spa's water pump(s) and heater. It is imperative that they are checked and tightened before filling the spa. Although every spa is thoroughly tested twice in our factory during final inspection, some connections may loosen during transport from the factory to your home.



2. Initial Preparation

Step 1: **Starting the spa with insufficient water can damage the pump and heater.** Once your spa is sufficiently filled (half way up the filter), turn the circuit breaker on.

Step 2: After turning on the circuit breaker, your spa will cycle through a series of self-diagnostic codes as indicated on the topside control panel.

Step 3: Wait 10 minutes so the spa can complete self-priming and diagnostic self-checks.

Step 4: If your topside control panel display shows the temperature, the temperature flashing, "ICE", or "--"; this is normal and you may proceed. If any other codes are shown, refer to troubleshooting guide located in the appendix or visit www.thermospas.com and click on Customer Center for more information.



3. Heat Water

Step 1: Set desired temperature by pressing "warm" or "cool" buttons.

Step 2: Install insulated cover, close it over spa, and secure it with the lock down straps.

Step 3: Allow between 5 and 24 hours for the water to reach the desired temperature.
A 240-volt service will raise it approximately 1° - 2°F per hour for the Spa Swimmer and Spa Trainer, and approximately 2° - 4°F for the Aquacisor.



4. Prep Water: Maintaining Correct Water Chemistry & Safety

Improper use of spa chemicals may be dangerous and could damage your hot tub and its cover. Since this damage is not covered by your warranty; it is extremely important to take precautions when using these products. Only use chemicals and cleaning agents designed for spas. Damage resulting from the use of non-recommended chemicals and/or cleaning agents is not covered under the warranty. Following the procedures in this guide will make the maintenance and care of your spa simple and economical.

Avoid using any biguanide or copper-based algaecides with your spa. Use of these products is not recommended by ThermoSpas and may void your warranty.

Proper Handling of Chemicals

1. Keep all chemicals out of reach of children.
2. Always keep lids on chemicals when not in use and store them in a cool, dry location away from direct sunlight
3. Do not store chemicals within the interior of the spa's cabinet.
4. Do not interchange caps or measuring scoops for different types of chemicals.
5. Do not smoke around chemicals. Some can emit highly flammable fumes.
6. In case of contact or if a chemical is swallowed, call a doctor or local Poison Control Center. If a doctor is required, bring the chemical container with you so the doctor can determine the appropriate treatment.
7. Never use swimming pool chemicals in your spa. They may void your warranty.
8. Never mix chemicals or chemical solutions directly with each other.
9. Always add chemicals to water when mixing them. Never add water to chemicals.
10. When in doubt, call Customer Care.

Proper Procedure For Adding Chemicals

Proper water chemistry is essential to the safety of the user as well to the life of the spa components. Improper water chemistry may cause skin irritation or facilitate the transmittal of disease. Proper water chemistry is the sole responsibility of the spa owner. The costs incurred from injury or damage resulting from improper water chemistry are not covered under the ThermoSpas, Inc. warranty.

1. Turn on all water pumps. This will ensure the added chemical(s) will be rapidly dispersed throughout the tub. Unless otherwise specified, all water pumps should run at least 10 minutes after a chemical treatment.
2. Remove a gallon or more of water from the spa and pre-dissolve the chemical. Pour the bucket with the dissolved chemicals back into the spa. This procedure insures complete solubility.
3. Only add one chemical at a time. Unless otherwise specified always wait at least 10 minutes after adding chemicals to your spa before adding more chemicals.

Note: Depending on the metals or mineral content of your tap water, one of the chemicals in the treatment may react to cause a discoloration or formation of a precipitate. In this event you should not have to drain your hot tub. There are treatments to solve this problem. If you have any questions contact Customer Care.

Chemical Start-Up

Your ThermoSpa has been delivered with a chemical starter kit. This kit allows you to choose between different sanitizing systems. The available sanitizing systems, start-up procedure, and chemical amounts necessary are different between larger spas such as the Spa Swimmer (abbreviated SS) and Spa Trainer (abbreviated ST), and conventional sized spas such as the Aquacisor.

Wait until water is heated to 80° F minimum and there is 4" or more of water in the spa.

Adjusting Hardness

Many areas of the country, especially those that have a municipal water source, tend to have soft water. Soft water may cause instant foaming and staining. Staining occurs because water has a natural demand for minerals and it attempts to satisfy this demand through the most readily available sources: heating elements, plumbing, etc. This corrosion is not only damaging to your equipment, but it also can stain your water and shell surface. All hot tub water should be tested for hardness levels.

Adjust the water's hardness if required. If you have any questions or concerns please contact ThermoSpas Customer Care prior to filling your spa.

Step 1: Get Hardness Strips

Step 2: Check Hardness According to Directions on Strip (100 - 200 Best, 200 - 400 Acceptable)

IF Below 100

Step 3: Add 4 Ounces of Liquid Calcium per 100 Gallons of spa water. Wait 30 minutes and retest. If still too low, repeat until the proper range is achieved.

IF Above 400

Step 4: Drain $\frac{1}{2}$ of the spa's water and replace with distilled water. Distilled water may be purchased at a pool water supplier.

Adjust Alkalinity & pH:

Balancing your water is just as important as sanitizing. Maintaining proper pH and alkalinity levels is essential for proper operation of a Hot Tub. Regardless of the sanitizing method used, improperly balanced water can cause your sanitizer to dissipate rapidly, increasing the risk of contamination. Balancing water is a two-part process: first you must correct alkalinity levels, then you must make sure your pH is within the proper range.

Step 1: Use Test Strips in Starter Kit

Step 2: Check Alkalinity According to Directions on Strip (Should be between 80ppm and 120ppm). Alkalinity is a measure of the pH buffering capacity of the spa's water, or the water's resistance to change pH. This must be adjusted first to get a true pH reading.

Step 3: **Below 80 IF alkalinity is too low**, premix 3 oz. (SS/ST)/ 1oz. (Aquacisor) pH/Alk Up with 1 gallon of spa water in a separate container and add back to the spa.
Above 120 IF alkalinity is too high, premix 3 oz. (SS/ST)/ 1oz. (Aquacisor) pH/Alk Down with 1 gallon of spa water in a separate container and add back to the spa.
 When adjusting alkalinity, never add more than 3 oz. (SS/ST)/ 1oz. (Aquacisor) at a time. Wait 20 minutes and retest. If still too low, repeat until the proper range is achieved. Do not exceed 9 oz. per day.

Step 4: Check pH According to Directions on Strip (Should be between 7.2 and 7.8). pH is a measure of the acidity of your spa's water. Low pH can cause pipes, motors, and seals to corrode, heaters to fail and skin discomfort. High pH can cause a condition called scaling, cloudy water and eye discomfort.

Step 5: **Below 7.2 IF pH is too low**, premix 2 oz. (SS/ST)/ $\frac{1}{2}$ oz. (Aquacisor) pH/Alk Up with 1 gallon of spa water in a separate container and add back to the spa.
Above 7.8 IF pH is too high, premix 2 oz. (SS/ST)/ $\frac{1}{2}$ oz. (Aquacisor) pH/Alk Down with 1 gallon of spa water in a separate container and add back to the spa.
 When adjusting pH, never add more than 2 oz. (SS/ST)/ 1 oz. (Aquacisor) at a time. Wait 20 minutes and retest. If still too low, repeat until the proper range is achieved. Do not exceed 6 oz. per day.

Sanitization Kit for Spa Swimmer/Spa Trainer

Choose

Three-Part Activated Bromine Start-Up

The **3-Part Activated Bromine System** combines two different Bromine systems- the Bromine tablet treatment and the two-Part Bromide sanitization system. The two-Part Bromide creates a reserve of bromine in the water while the tablets continually activate it. The result is total bromine sanitization for the larger spas.

Step 1: Add 8 oz. Protection Plus to the spa.

Step 2: Add 2 oz. Natural & Clear to spa water.

Step 3: Add 32 oz. of Bromide Liquid Salts to the spa water.

Step 4: Place 6 tablets in dispenser and place in spa.

Step 5: Open Feeder so that half of holes are open.

Step 6: Wait 3 hours then shock spa with 6 oz. Activator to start Bromine reserve.

Step 7: Remove dispenser each time you use the spa.

Chlorine Start-Up

Or

Chlorine Sodium Dichlor is considered the most effective chemical sanitizer you can use in a spa. Features include less chance of staining because it is such a good oxidizer; pH neutral so it does not throw off your pH reading, and it is highly soluble and fast acting.

- Step 1:** Add 8 oz. Protection Plus to the spa.
- Step 2:** Add 2 oz. Natural & Clear to spa water
- Step 3:** Shock spa with 6 oz. of Spa Chlorine
- Step 4:** Wait 1 hour then add 6 oz. of Chlorinating Granules to the spa water
- Step 5:** Wait 15 minutes and test chlorine level. Level should be between 1-3ppm, if not, add 4 oz. more.

Sanitization Kit For Aquacisor

Bromine Tabs Start-Up

Choose

Bromine Tablets are a very simple sanitization to use. Bromine tablets are a combination of 70% Sodium Bromide and 30% Chlorine. The tablets are inserted into a dispenser that floats in the water providing continuous disinfection. And because it is only 30% Chlorine, the scent is reduced greatly.

- Step 1:** Add 3 oz. Stain & Scale to the spa.
- Step 2:** Add 1 oz. Natural & Clear to spa water
- Step 3:** Place 2 tablets in dispenser and place in spa.
- Step 4:** Open Feeder so that half of holes are open.
- Step 5:** Wait 15 minutes then shock spa with 2 oz. Activator to start Bromine reserve.
- Step 6:** Remove dispenser each time you use the spa.

Two-Part Bromide Start-Up

Or

Two-Part Bromide: The two parts of this system are Bromide Liquid Salts (sanitizer) and Spa Activator (activator). Bromide Liquid Salts is a water solution of sodium bromide which is the primary sanitizing agent for your spa. Spa Activator is a granular based oxidizing agent that contains no chlorine or bromine, but activates the sanitizer. This two-part system is pH neutral and is considered the most effective sanitizing system on the market.

- Step 1:** Add 3 oz. Stain & Scale to the spa.
- Step 2:** Add 1 oz. Natural & Clear to spa water
- Step 3:** Add 8 oz. of Bromide Liquid Salts to the spa water.
- Step 4:** Wait 15 minutes then shock spa with 2 oz. Activator to start Bromine reserve.

Chlorine Start-Up

Or

Chlorine Sodium Dichlor is considered the most effective chemical sanitizer you can use in a spa. Features include less chance of staining because it is such a good oxidizer; pH neutral so it does not throw off your pH reading, and it is highly soluble and fast acting.

- Step 1:** Add 3 oz. Stain & Scale to the spa.
- Step 2:** Add 1 oz. Natural & Clear to spa water
- Step 3:** Add 2 teaspoons of Chlorinating Granules to the spa water
- Step 4:** Wait 15 minutes and test chlorine level. Level should be between 1-3ppm, if not, add 1 teaspoon more.

Spas With ThermOzone

ThermOzone accomplishes water sanitization by using a powerful oxidant, Ozone. This 100% organic compound reacts with and destroys bacteria, mold, Fungus, etc. Through a proprietary process, ozone effectiveness and air quality are maximized to provide optimal sanitation of your spa.

Components

- A Ozone Generator** – Using Corona discharge technology, the Ozone generator delivers 250 mg of Ozone per hour to the Mixing Vessel.
- B Mixing Vessel** – Using Venturi action, the Mixing Vessel pulls ozone from the Generator and mixes with Spa water fed from the circulation pump. This is where the sanitization occurs. An overflow tube feeds unused ozone to the carbon filter but an internal valve keeps water from entering the carbon filter. Treated water is sent back to the spa via the ozone jet.
- C Carbon Filter** – Any excess ozone is passed through the Carbon Filter and is neutralized of its oxidation effectiveness, releasing harmless oxygen underneath your cabinet.
- D Ozone Fitting** – A special fitting provides a return back to the spa for the treated water.

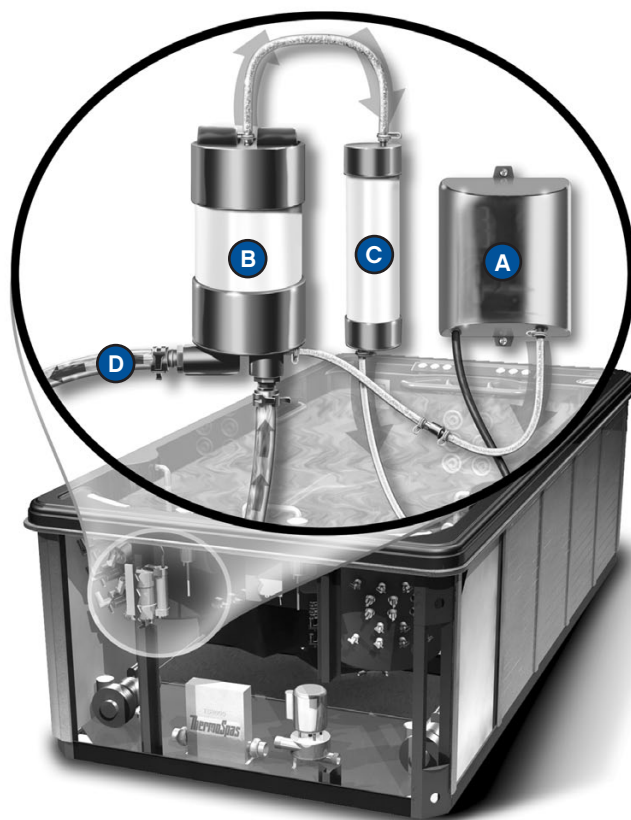

Operation

In spas equipped with a circulation pump, the ThermOzone system is active any time the circulation pump is running.

Chemical Usage

- A. Spas that have ThermOzone installed should maintain a 0.5 ppm Chlorine level or a 1.0 ppm Bromine Level.
- B. Depending on your usage, and if your water is clear, you can continue to reduce the amount of chemicals you are using by trying to add sanitizer on a once weekly schedule, and performing the rest of your weekly maintenance (Stain & Scale, Natural & Clear etc...) on a Bi-Weekly basis.
- C. For ThermOzone to work more efficiently, please remember to clean your filters bi-weekly. Make sure you go no longer than one month between filter cleanings.

Note: If water becomes cloudy, please resume all chemical maintenance on a regular weekly basis. If your usage increases, you may have to add an additional sanitizer treatment in the middle of the week.

On-Going Spa Maintenance

Once you have initially set up your spa there will be on-going maintenance required to keep your spa and your hot tub experience in top shape. The following sections outline alternative sanitizer choices, on-going maintenance, guidelines and references to help you easily maintain your spa for years to come.

Your ThermoSpa came with a chemical starter kit but the sanitizer method may vary depending on what you chose when you purchased your spa. If you would like to use an alternative sanitization method to the one used to start up your spa, the products you will need and the procedure you should follow are listed in detail. In most cases, sanitization methods are not compatible with one another. In order to change sanitization methods, you must drain your spa and flush the plumbing lines with ThermoSpas Jet Line Cleaner in order to remove all conflicting sanitizer residues from inside your spa's plumbing.

Sanitizer Comparisons

All spas require sanitizer. Unsanitized spa bacteria may double every 30 minutes.

Wait at least 10 minutes after the addition of Stain & Scale or Protection Plus during filling before adding any sanitizer.

	Ease of Use	Fast Acting	Water Clarity	Skin Sensitivity	pH Neutral	Requires Shocking	Odor Free	Drain & Fill Frequency	Frequency of Application	Compatible with ThermoOzone	Effective in Large Spas	
ThermoClear	○	●	●	●	●	●	●	○	○	○	○	● Good
Chlorine	○	●	●	●	●	○	●	●	●	●	●	○ Better
Bromine Tablets	●	○	●	●	●	●	●	○	○	●	●	● Best
2-Part Bromine	●	○	●	○	●	○	●	○	○	○	○	
3-Part Activated Bromine	●	○	●	○	●	○	○	○	○	●	●	

Spa Chemical Maintenance Program - Chlorine (Spa Swimmer/Spa Trainer and Aquacisor)

Note: Chemical amounts differ for the Spa Swimmer/Spa Trainer and the Aquacisor due to water volume.

What You Will Need

WT1007 - Protection Plus (SS/ST only)	TS1003 - Chlorine Test Strips
WT1001 - Stain & Scale (Aquacisor only)	WB1001 - pH/Alk Up
WT1003 - Natural & Clear	WB1002 - pH Alk Down
SP1003 - Sodium Dichlor	SP1008 - Activator (Weekly Shock)

Start Up (Always make sure all pump unions are tight)

1. Set up your water maintenance

- All water comes with certain minerals and impurities. These chemicals help get your water clear and ready for use.
- Fill Spa to half way mark of skimmer
 - Add 8 oz. of Protection Plus (SS/ST) or 3oz. Stain & Scale (Aquacisor) when there is 4" or more of water in the bottom of the Spa.
 - Add 2 oz. (SS/ST)/ 1 oz. (Aquacisor) of Natural & Clear when there is 4" or more of water in the bottom of the Spa.
- Wait until water is above 80 degrees

2. Balance your water

- Alkalinity and pH measure the acidity of your water. Step 2 helps you balance your water to prevent skin irritation and corrosion of spa parts.
 - Test Alkalinity/pH with the test strips provided in your starter kit
 - Alkalinity should measure between 80 - 120
 - pH should measure between 7.2 - 7.8
 - Adjust your Alkalinity first to the proper range
 - If adjustment is needed add 3 oz. (SS/ST)/ 1 oz. (Aquacisor) of Alkalinity/pH Up or Down to spa water.
 - Check Alkalinity after 15 minutes and adjust as necessary
 - Check your pH next to balance water fully
 - If adjustment is needed add 2 oz. (SS/ST)/ 1/2 oz. (Aquacisor) of Alkalinity/pH Up or Down to spa water.
 - Check pH after 15 minutes and adjust as necessary

3. Sanitize your water

- Sanitization keeps your water free of harmful bacteria, viruses and other organic matter that can cause your water to be cloudy.
 - Spa Swimmer/Spa Trainer Only: Shock Spa with 6 oz. of Spa Activator
 - Wait one hour, then add 6 oz. (SS/ST)/ 1 oz. (Aquacisor) of Spa Chlorine

On-Going Maintenance

1. Water maintenance

- Add 2 oz. of Protection Plus (SS/ST)/ 1 oz. of Stain & Scale (Aquacisor) to sequester metals and impurities once a week
- Wait 15 minutes, then add 2 oz. (SS/ST)/ 1/2 oz. (Aquacisor) of Natural & Clear to remove oils once a week

2. Balance your water

- Check pH and Alkalinity once a week and adjust as necessary

3. Sanitize your water

- Shock Spa with 6 oz. (SS/ST)/ 2 oz. (Aquacisor) of Activator once a week
- Check Chlorine level two to three times a week to insure 5 ppm** of Chlorine. Adjust if necessary.
 - If low add 4 oz. (SS/ST)/ 1/2 teaspoons (Aquacisor) of Sodium Dichlor

Monthly Maintenance

Perform your normal weekly maintenance and add Step 4.

4. Clean your spa

- Wipe your acrylic shell - clean dust, water spots, chemical stains etc...
- Clean and condition your cover, page 32.
- Clean your Filters - Soak in cleaning solution, rinse and dry thoroughly before using. (You may have to do this every other week if you use your spa more than four times a week.)
- Check water in Spa Fill Spa to half way mark of skimmer.

**Note: If you are using ThermOzone, you may try to reduce your sanitizer level to a once to twice a week application and maintain a .5 ppm Chlorine level.

Spa Chemical Maintenance Program - Three-Part Activated Bromine System (Spa Swimmer/Spa Trainer Only)

What You Will Need

WT1007 - Protection Plus	WT1003 - Natural & Clear
SP1004 - Bromide Liquid Salts	SP1004 - Bromine Tabs
WB1001 - pH/Alk Up	WB1002 - pH Alk Down
TS1002 - Bromine Test Strip	SP1008 - Activator (Weekly Shock)
Floating Dispenser	

Start Up (Please make sure all pump unions are tight)

1. Set up your water maintenance

- All water comes with certain minerals and impurities. These chemicals help get your water clear and ready for use.
- Fill Spa to half way mark of skimmer
 - Add 8 oz. of Protection Plus when there is 4" or more of water in the bottom of the Spa.
 - Add 2 oz. of Natural & Clear when there is 4" or more of water in the bottom of the Spa.
- Wait until water is above 80 degrees

2. Balance your water

- Alkalinity and pH measure the acidity of your water. Step 2 helps you balance your water to prevent skin irritation and corrosion of spa parts.
 - Test Alkalinity/pH with the test strips provided in your starter kit
 - Alkalinity should measure between 80 - 120
 - pH should measure between 7.2 - 7.8
 - Adjust your Alkalinity first to the proper range
 - If adjustment is needed add 3 oz. of Alkalinity/pH Up or Down to spa water.
 - Check Alkalinity after 15 minutes and adjust as necessary
 - Check your pH next to balance water fully
 - If adjustment is needed add 2 oz. of Alkalinity/pH Up or Down to spa water.
 - Check pH after 15 minutes and adjust as necessary

3. Sanitize your water

- Sanitization keeps your water free of harmful bacteria, viruses and other organic matter that can cause your water to be cloudy.
 - Add 32 oz. Bromide Liquid Salts to water
 - Place 6 tablets in dispenser and place in spa
 - Open Feeder to the halfway mark (cover half of holes)
 - Wait 3 hours and shock spa with 6 oz. of Activator to start Bromine reserve.

On-Going Maintenance

1. Water maintenance

- Add 2 oz. of Stain & Scale to sequester metals and impurities once a week
- Wait 15 minutes, then add 2 oz. of Natural & Clear to remove oils once a week

2. Balance your water

- Check pH and Alkalinity once a week and adjust as necessary

3. Sanitize your water

- Check Bromine Level two to three times a week to insure a 2 - 4 ppm** Bromine level
 - If Bromine levels are low
 - Open Feeder to provide more Bromine to the spa
 - Add 6 oz. of Activator to Spa as a shock
 - If Bromine levels are high, close Feeder by 1-2 holes to reduce bromine level
 - Add tablets as necessary

Monthly Maintenance

Perform your normal weekly maintenance and add Step 4.

4. Clean your spa

- Wipe your acrylic shell - clean dust, water spots, chemical stains etc...
- Clean and condition your cover; page 32.
- Clean your Filters - Soak in cleaning solution, rinse and dry thoroughly before using. (You may have to do this every other week if you use your spa more than four times a week.)
- Check water in Spa Fill Spa to half way mark of skimmer.

***Note: If you are using ThermOzone, you may try to reduce your sanitizer level to once weekly maintenance only. You should maintain a 1 ppm Bromine level.*

Spa Chemical Maintenance Program - Bromine Tabs (Aquacisor Only)

What You Will Need

WT1001 - Stain & Scale	WT1003 - Natural & Clear
SP1004 - Bromine Tabs	Floating Dispenser
WB1001 - pH/Alk Up	WB1002 - pH Alk Down
TS1002 - Bromine Test Strip	SP1008 - Activator (Weekly Shock)

Start Up (Please make sure all pump unions are tight)

1. Set up your water maintenance

- All water comes with certain minerals and impurities. These chemicals help get your water clear and ready for use.
- Fill Spa to half way mark of skimmer
 - Add 3 oz. of Stain & Scale when there is 4" or more of water in the bottom of the Spa.
 - Add 1 oz. of Natural & Clear when there is 4" or more of water in the bottom of the Spa.
- Wait until water is above 80 degrees

2. Balance your water

- Alkalinity and pH measure the acidity of your water. Step 2 helps you balance your water to prevent skin irritation and corrosion of spa parts.
 - Test Alkalinity/pH with the test strips provided in your starter kit
 - Alkalinity should measure between 80 - 120
 - pH should measure between 7.2 - 7.8
 - Adjust your Alkalinity first to the proper range
 - If adjustment is needed add 1 oz. of Alkalinity/pH Up or Down to spa water.
 - Check Alkalinity after 15 minutes and adjust as necessary
 - Check your pH next to balance water fully
 - If adjustment is needed add 1/2 oz. of Alkalinity/pH Up or Down to spa water.
 - Check pH after 15 minutes and adjust as necessary

3. Sanitize your water

- Sanitization keeps your water free of harmful bacteria, viruses and other organic matter that can cause your water to be cloudy.
 - Place 2 tablets in dispenser and place in spa
 - Open Feeder to the half way mark (count total number of holes on the Feeder; cover half)
 - Wait 15 minutes and shock spa with 2 oz. of Activator to start Bromine reserve.

On-Going Maintenance

1. Water maintenance

- Add 1 oz. of Stain & Scale to sequester metals and impurities once a week
- Wait 15 minutes, then add 1/2 oz. of Natural & Clear to remove oils once a week

2. Balance your water

- Check pH and Alkalinity once a week and adjust as necessary

3. Sanitize your water

- Check Bromine Level twice a week to insure a 2 - 4 ppm** Bromine level
 - If Bromine levels are low
 - Open Feeder to provide more Bromine to the spa
 - Add 2 oz. of Activator to Spa as a shock
 - If Bromine levels are high, close Feeder by 1 - 2 holes to reduce bromine level.
 - Add Tablets if necessary - Never add more than 2 tablets into dispenser at a time

Monthly Maintenance

Perform your normal weekly maintenance and add Step 4.

4. Clean your spa

- Wipe your acrylic shell - clean dust, water spots, chemical stains etc...
- Clean and condition your cover; page 32.
- Clean your Filters - Soak in cleaning solution, rinse and dry thoroughly before using. (You may have to do this every other week if you use your spa more than four times a week.)
- Check water in Spa Fill Spa to half way mark of skimmer.

**Note: If you are using ThermOzone, you may try to reduce your sanitizer level to once weekly maintenance only. You should maintain a 1 ppm Bromine level.

Spa Chemical Maintenance Program - Two-Part Bromide (Aquacisor Only)

What You Will Need

WT1001 - Stain & Scale
 SP1004 - Bromide Liquid Salts
 WB1001 - pH/Alk Up
 TS1002 - Bromine Test Strip

WT1003 - Natural & Clear
 WB1002 - pH Alk Down
 SP1008 - Activator (Weekly Shock)

Start Up (Please make sure all pump unions are tight)

1. Set up your water maintenance

- a. All water comes with certain minerals and impurities. These chemicals help get your water clear and ready for use.
- b. Fill Spa to half way mark of skimmer
 - i. Add 3 oz. of Stain & Scale when there is 4" or more of water in the bottom of the Spa.
 - ii. Add 1 oz. of Natural & Clear when there is 4" or more of water in the bottom of the Spa.
- c. Wait until water is above 80 degrees

2. Balance your water

- a. Alkalinity and pH measure the acidity of your water. Step 2 helps you balance your water to prevent skin irritation and corrosion of spa parts.
 - i. Test Alkalinity/pH with the test strips provided in your starter kit
 1. Alkalinity should measure between 80 - 120
 2. pH should measure between 7.2 - 7.8
 - ii. Adjust your Alkalinity first to the proper range
 1. If adjustment is needed add 1 oz. of Alkalinity/pH Up or Down to spa water.
 2. Check Alkalinity after 15 minutes and adjust as necessary
 - iii. Check your pH next to balance water fully
 1. If adjustment is needed add 1/2 oz. of Alkalinity/pH Up or Down to spa water.
 2. Check pH after 15 minutes and adjust as necessary

3. Sanitize your water

- a. Sanitization keeps your water free of harmful bacteria, viruses and other organic matter that can cause your water to be cloudy.
 - i. Add 8 oz. Bromide Liquid Salts to water
 - ii. Wait 5 minutes and shock spa with 2 oz. of Activator to start Bromine reserve.

On-Going Maintenance

1. Water maintenance

- a. Add 1 oz. of Stain & Scale to sequester metals and impurities once a week
- b. Wait 15 minutes, then add 1/2 oz. of Natural & Clear to remove oils once a week.

2. Balance your water

- a. Check pH and Alkalinity once a week and adjust as necessary

3. Sanitize your water

- a. Check Bromine Level two to three times a week to insure a 2 - 4 ppm** Bromine level
 - i. If Bromine levels are low
 1. Add 4 oz. Bromide Liquid Salts
 2. Add 2 oz. of Activator to Spa as a shock

Monthly Maintenance - Two-Part Bromide

Perform your normal weekly maintenance and add Step 4.

4. Clean your spa

- a. Wipe your acrylic shell - clean dust, water spots, chemical stains etc...
- b. Clean and condition your cover, page 32.
- c. Clean your Filters - Soak in cleaning solution, rinse and dry thoroughly before using. (You may have to do this every other week if you use your spa more than four times a week.)
- d. Check water in Spa Fill Spa to half way mark of skimmer.

***Note: If you are using ThermOzone, you may try to reduce your sanitizer level to once weekly maintenance only. You should maintain a 1 ppm Bromine level.*

Spa Chemical Maintenance Program - ThermoClear (Only For use in spas of less than 500 gallons)

What You Will Need

WT1001 - Stain & Scale	WB1001 - pH/Alk Up
WT1003 - Natural & Clear	WB1002 - pH Alk Down
SP1003 - Sodium Dichlor (Weekly Shock)	SP1008 - Activator
TS1001 - ThermoClear Test Strips	ThermoClear Cartridge

Start Up (Please make sure all pump unions are tight)

1. Set up your water maintenance

- All water comes with certain minerals and impurities. These chemicals help get your water clear and ready for use.
- Fill Spa to half way mark of skimmer
 - Add 3 oz. of Stain & Scale when there is 4" or more of water in the bottom of the Spa.
 - Add 1 oz. of Natural & Clear when there is 4" or more of water in the bottom of the Spa.
- Wait until water is above 80 degrees

2. Balance your water

- Alkalinity and pH measure the acidity of your water. Step 2 helps you balance your water to prevent skin irritation and corrosion of spa parts.
 - Test Alkalinity/pH with the test strips provided in your starter kit
 - Alkalinity should measure between 80 - 120
 - pH should measure between 7.2 - 7.8
 - Adjust your Alkalinity first to the proper range
 - If adjustment is needed add 1 oz. of Alkalinity/pH Up or Down to spa water.
 - Check Alkalinity after 15 minutes and adjust as necessary
 - Check your pH next to balance water fully
 - If adjustment is needed add 1/2 oz. of Alkalinity/pH Up or Down to spa water.
 - Check pH after 15 minutes and adjust as necessary

3. Sanitize your water

- Sanitization keeps your water free of harmful bacteria, viruses and other organic matter that can cause your water to be cloudy.
 - Insert new ThermoClear Cartridge
 - Shock Spa with 2 oz. of Activator

On-Going Maintenance

- Add 2 oz. of Activator every time you enter the spa**.
- If in tub for more than 30 minutes - add 2 oz. Activator upon exiting

Weekly Maintenance - ThermoClear

1. Water maintenance

- Add 1 oz. of Stain & Scale to sequester metals and impurities
- Wait 15 minutes, then add 1/2 oz. of Natural & Clear to remove oils

2. Balance your water

- Check pH and Alkalinity and adjust as necessary

3. Sanitize your water

- Shock Spa with 1 tablespoon of chlorine

Monthly Maintenance

Perform your normal weekly maintenance and add Step 4.

4. Clean your spa

- Wipe your acrylic shell - clean dust, water spots, chemical stains etc...
- Clean and condition your cover; page 32.
- Clean your Filters - Soak in cleaning solution, rinse and dry thoroughly before using. (You may have to do this every other week if you use your spa more than four times a week.)
- Check water in Spa Fill Spa to half way mark of skimmer.

***Note: If you are using ThermoOzone, you may try to reduce your use of Activator to every other use. If water remains clear continue to reduce Activator use to a once to twice a week application. Continue to shock tub with Chlorine once a week.*

Water Chemistry Maintenance

Action	Frequency
<p>1. Test and Balance Alkalinity:</p> <p>There are three products needed to test and balance alkalinity:</p> <ul style="list-style-type: none"> • Test Strip: provides a reading on the alkalinity level; • pH/Alkalinity Up: raises the alkalinity level; and • pH/Alkalinity Down: lowers the alkalinity level <p>The acceptable alkalinity level must range between 80-120 ppm (parts per million). Follow the Adjust Alkalinity/pH.</p>	Bi-Weekly
<p>2. Test and Balance pH</p> <p>There are three products needed to test and balance pH:</p> <ul style="list-style-type: none"> • Test Strips: tests the pH level; • pH/Alkalinity Up: raises the pH level; and • pH/Alkalinity Down: lowers the pH level <p>The acceptable pH level must range between 7.2 – 7.8. Do not enter your spa if the pH level is out of range, or you risk the possibility of skin and eye irritation.</p>	Bi-Weekly
<p>3. Test Total Dissolved Solids (TDS)</p> <p>Increases in Total Dissolved Solids will cause your sanitizer to become ineffective. Once Total dissolved solids have reached a level of 3000 ppm your water should be changed.</p> <ul style="list-style-type: none"> • Use test strips to check level of Total dissolved solids. • If the reading is 3,000 ppm or less, the spa requires no maintenance. 	Monthly
<p>4. Treatment of Minerals and Metals</p> <p>Control any staining or discoloring of the water caused by minerals with ThermoSpas Stain & Scale and Protection Plus. Both chemicals sequester metals, but Protection Plus is specially formulated for larger spas or exceptionally hard water. Using these chemicals helps prevent scale from forming on the shell's surface and/or any corrosion occurring to the heater element.</p> <ul style="list-style-type: none"> • To have your water tested for mineral content, send a water sample to ThermoSpas' Customer Care Department for a free analysis. • For weekly water maintenance add Stain & Scale or Protection Plus. 	Weekly
<p>5. Treatment of Oils and Organics</p> <p>Bathers bring lotions, skin, hair and other organics into spas. Using a natural enzyme that breaks down and devours oils and other organics that sanitizers cannot destroy is essential to maintaining clear water. ThermoSpas Natural & Clear immediately breaks down the organics by converting them into a gas before they can interfere with the sanitizers' performance. Because it dissolves the organics as opposed to coagulating the organics like most other clarifiers used by competitors, Natural & Clear helps rid the acrylic shell of the unsightly "scum line" above the water's surface.</p> <ul style="list-style-type: none"> • For weekly water maintenance add Natural & Clear. 	Weekly
<p>6. Excessive Foaming</p> <p>To correct foaming caused by soap or other residues, use ThermoSpas Foam Away. Make certain to shake container and disperse 2-3 capfuls for Spa Swimmer/ Spa Trainer; only ONE capful for Aquacisor where foaming is occurring while water is circulating. Wait 30 minutes and repeat treatment if foaming continues. It is recommended to clean your filter within 24 hours of using Foam Away. Using too much Foam Away will cloud your water; taking as much as 24 hours to dissipate. Add only 1 capful at a time and please be patient.</p>	As Required
<p>7. Cleaning Biofilm in your spa plumbing lines</p> <p>Over time biofilm can accumulate in your spa's plumbing lines. Using a Jet Line cleaner at least twice a year is recommended to ensure excessive growth of bacteria does not cause increased use of sanitizers.</p>	Drain and Refill

Basic Spa Maintenance

Keeping your ThermoSpa operating for maximum enjoyment requires a simple maintenance routine. Following the procedures below at the recommended intervals will insure that your spa provides years of service. If you have any questions concerning the maintenance of your spa please contact ThermoSpas' Customer Care department.

Item	Frequency
Check Water level and Condition OF Spa	Daily
Check Cover	Daily
Check Spa Temperature	Daily
Check For Foreign Objects or Debris in Spa	Daily
Clean Shell Above Water Line	Weekly
Clean Filter(s)	3 weeks Max. and at each drain & refill
Drain and ReFill Spa	6 months
Flush and Clean Lines	Each Drain & ReFill
Clean the Spa Cover	Monthly
Clean and Protect Cabinet	As recommended

1. Daily Maintenance

- Check for leaks by walking around the spa and looking at the base of the cabinet for signs of water.
- Be sure the spa cover is in place and tied down to the spa.
- Check spa temperature
- Look for any signs of external damage to the spa and spa cover
- Remove any foreign objects or debris that may have fallen into the spa

2. Check Sanitizer Level

- Check sanitizer level and adjust as necessary, two to three times a week

3. Weekly Maintenance

- Add metal sequestering chemicals - ThermoSpas Stan & Scale or Protection Plus
- Add Enzymes - ThermoSpas Natural & Clear
- Shock Spa

4. Scheduled Maintenance

- **Clean the shell above the water line with ThermoSpas All Purpose Cleaner once a week.**
 - All Purpose Cleaner will not alter the water chemistry, or scratch the acrylic shell.
 - ThermoSpas does not recommend the use of household cleaners on the spa shell. Most will alter the water chemistry and some contain abrasives that will scratch and dull the spa shell.
 - The Scum Mitt offered by ThermoSpas is ideal for use with the All Purpose Cleaner.
- **Clean the spa filter(s) at least every 1-3 weeks depending upon usage.**
 - Follow the cleaning process outlined in this manual. Additional information relating to filter maintenance may be found in the Special Operation Instructions that came with your spa.
 - If the spa is used heavily the filters should be cleaned at more frequent intervals.
 - Having a second set of filters on hand is strongly recommended as they greatly reduce the down time the spa requires for filter maintenance.
- **Drain and refill the spa every 6 months.**
 - Follow the drain and refill procedures in this manual.
 - Each time the spa is drained and refilled the lines should be flushed and cleaned. Follow the procedure outlined in this manual.
 - It is recommended the entire shell surface be cleaned and protected each time the spa is drained and refilled. Use All Purpose Cleaner and ThermoGloss as outlined in the procedure in this manual.
 - The filter(s) should be cleaned with each drain and refill. See this manual and the Special Operating Instructions that came with your spa.
 - Spas that are used heavily will require more frequent drain and refill cycles.
- **Condition the Cover Monthly.**
 - The cover should be thoroughly cleaned and conditioned once a month using ThermoSpas Cover Conditioner. Any foreign matter should be removed regularly.
- **Clean and Protect the Cabinet.**
 - Cabinets constructed of ThermoBoard require hosing and wiping down once or twice a year.
 - Cabinets constructed of cedar require washing, sanding and restaining a minimum of four times a year.

Changing/Cleaning Filters

We strongly recommend that you clean the Filter every one to three weeks depending on how often your spa is used. Just because a Filter is dirty does not mean it needs to be replaced. Filters that are cleaned regularly can last up to 12 months.

To determine whether your Filter needs replacing look within the pleats of the Filter inspecting for any build up of grime and dirt particles after cleaning. If dirt particles remain the Filter should be replaced. Filters are not designed to last more than 12 months. We recommend using ThermoSpas Filter Clean to clean the Filter(s) in your spa.

Note: Some ThermoSpas hot tubs use two or more filters. Refer to the "Special Operating Instructions" sheet for your spa model for specific information about the type of filter system it has and how to access the filter(s).

- Step 1:** Refer to your spa's "Special Operating Instructions" sheet for information on how to remove the Filter(s) for cleaning.
- Step 2:** Place the Filter(s) in an appropriate container and fill with water.
- Step 3:** Add 8 oz. of ThermoSpas Filter Clean to the bucket of water. If there are excessive mineral deposits on the Filter(s), you may need to double the amount to 16 oz. of Filter Clean.
- Step 4:** Mix the solution in the bucket by moving the Filter(s) up and down several times.
- Step 5:** Allow the Filter(s) to soak for 12-24 hours.
- Step 6:** After soaking, remove the Filter(s) from the solution and rinse out any remaining debris using a garden hose or pressure sprayer. Allow Filters to air dry naturally.

Tip: You may want to have extra Filter cartridges on hand. This will help you prolong the life of your spa by allowing ample time for dirty cartridge(s) to soak. It will also enable you to enjoy your spa while the dirty cartridge(s) are going through the cleaning process. **Filters should be completely air dried before returning to the hot tub. Damp Filters carry bacteria on them that could contaminate your spa water.**

- Step 7:** When replacing Filters, the pressurized circulation system must be primed. For the Spa Swimmer/Spa Trainer, ensure that the spa is in Standby mode (by pressing Cool, then Pump 2) and the circulation pump has stopped running. Open the Pressure Relief Valve and listen for all air to escape and retighten. Press any button to exit Standby mode. For the Aquacisor, ensure that the circulation pump is running, then open the Pressure Relief Valve until water begins to flow, then retighten.

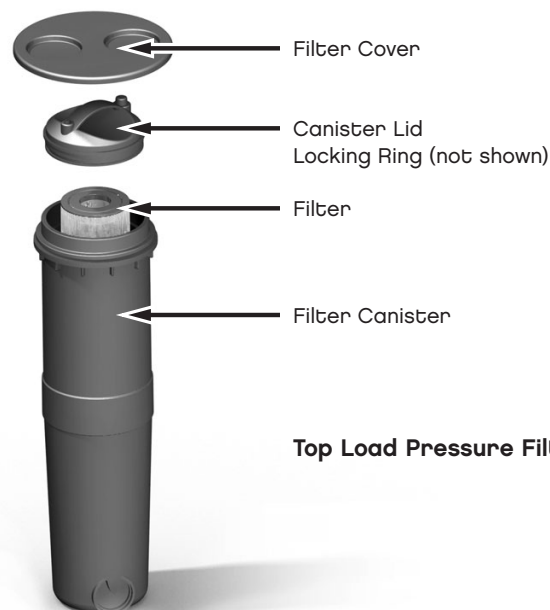

Top Load Pressure Filter Assembly

Drain & Refill

Drain and refill the spa at least every 6 months. It is recommended that the plumbing lines be flushed and cleaned each time the spa is drained.

- Step 1:** Set the temperature on the digital control panel to its lowest temperature setting.
- Step 2:** Turn the spa circuit breaker off.
- Step 3:** Drain your spa. The ideal way to drain a spa is with a submersible pump. If you don't have a submersible pump, you can attach a garden hose to the drain fitting. Once the hose is attached, open the drain fitting. This will enable the water in the spa to gravity drain. For faster draining, use both a submersible pump and the drain fitting.
- Step 4:** Use a foam sponge, mop, or wet/dry vacuum to remove any remaining water left in the bottom of the spa footwell or in seating areas.
- Step 5:** Completely dry the shell surface with a soft, clean cloth.
- Step 6:** Clean the shell surface of any debris or mildew using ThermoGloss and Multi Purpose Cleaner
- Tip:** This is also an excellent time to change and clean the spa's filter(s)
- Step 7:** You are now ready to refill the spa.

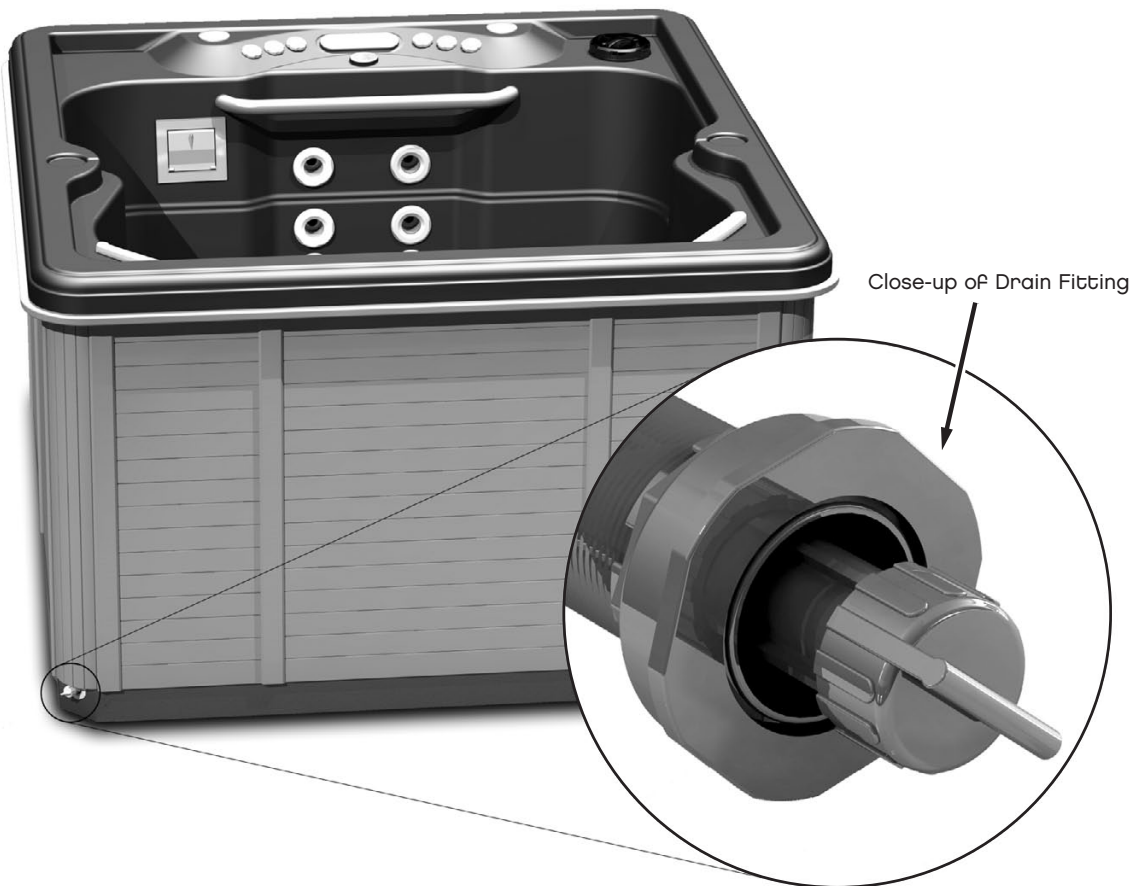
**WARNING**

Use caution when attaching a hose to the external drain fitting. Excess strain while the fitting is extended can cause it to break.

Cleaning the Cover

While your vinyl cover is made to withstand the elements, it is important to care for it by keeping it clean at all times. Many contaminants may stain the vinyl if left on over a period of time. Remove debris immediately!

Conditioning the Cover

Conditioning the spa cover monthly will prolong its life. We recommend using ThermoSpas Cover Conditioner. It helps keep vinyl from hardening and cracking, and is especially effective for covers exposed to harsh outdoor elements like the sun's ultra-violet rays, snow, and sleet. Cover Conditioner should only be used on the topside of the cover. To clean the underside of the cover simply use a garden hose and a 2:1 mix of water and vinegar. Allow cover to dry.

- Step 1:** Apply ThermoSpas Cover Conditioner Full strength with a damp sponge or soft brush.
- Step 2:** Leave the conditioner on the cover for three minutes. Areas with excessive dirt or residue build-up may need extra scrubbing.
- Step 3:** Wipe the cover clean with a damp sponge or cloth.
- Step 4:** Rinse the cover with water.



Do not use petroleum-based vinyl cleaning products because they may be harmful to the cover and will void its warranty.

Flushing Lines

There are many plumbing lines in a spa. No matter how clean you keep the water, chemicals clean only the water, not the plumbing lines. Bacteria and mildew-attracting scum can accumulate in the vast number of spa plumbing lines and fittings. You need to flush and clean them to prolong the life of your spa and keep it running smoothly.

Flushing and cleaning needs to be done every 6 months to one year, or if you notice a film developing around the spa fittings. You should perform this procedure just before you drain your spa. We recommend using ThermoSpas Jet Line Cleaner to dissolve the build up of body oils, dirt, hair, soap, scum, rust and mineral deposits which are the perfect breeding ground for bacteria and mold.

- Step 1:** Remove filter(s) and clean.
- Step 2:** Before spa is drained, empty contents of 2 bottles ThermoSpas Jet Line Cleaner (16 fl. oz.) for Spa Swimmer/Spa Trainer; 1 bottle Jet Line Cleaner (16 fl. oz.) for Aquacisor in to warm spa water.
- Step 3:** Turn pump(s) "on" and run jets for 15 minutes. (Ensure filter is not in spa and cover is closed.)
- Step 4:** Turn pump(s) and jets "off" and let sit for 1 hour.
- Step 5:** Turn pump(s) "on" and run jets for 15 minutes.
- Step 6:** Drain the spa, hosing off the inside walls while draining.
- Step 7:** Refill the spa.

Note: Some residual foaming may occur; if so, use ThermoSpas Foam Away to suppress foam.

Shell Surface Cleaning

Cleaning Above the Water Line

The perfect product for cleaning the shell surface above the water line (when the spa is filled) is ThermoSpas Multi Purpose Cleaner. This helps to prevent a scum line from forming. Because it is a natural enzyme, it will not affect the water's chemistry, it's safe to use, it won't scratch the acrylic, and it helps to eliminate mold or mildew odors without bleaching the surface.



Beware of using products such as Windex, as they will alter the water's chemistry; or other abrasive cleansers that can scratch the acrylic surface.

Step 1: Spray the exposed surface area of the shell above the waterline with Multi Purpose Cleaner. This will not affect the water chemistry.

Step 2: Wait a few minutes and then simply wipe away the grime with a soft cloth or damp sponge. For heavily soiled areas, spray generously, wait five minutes and scrub with a sponge. ThermoSpas offers an accessory called the Mytee Mitt which is perfect for this use.

Deep Cleaning the Entire Shell Surface

Anytime the spa is drained and dry, we recommend two products when cleaning the entire shell surface: ThermoGloss and Multi Purpose Cleaner. ThermoGloss helps create a hard, durable, protective coating on the shell that seals the surface and hides scratches in the acrylic. Multi Purpose Cleaner is ideal for ridding the surface of any dry residue.



Do not use car wax of any kind.

Step 1: Remove any scum lines using Multi Purpose Cleaner.

Step 2: Shake ThermoGloss well before using and apply only on the shell surface. The surface should be completely dry upon application.

Step 3: Spread evenly using an overlapping circular motion.

Step 4: Allow the ThermoGloss to dry, spray Multi Purpose Cleaner on the dry residue left by the ThermoGloss, and wipe the shell surface clean with a dry, soft cloth.

Closing Your Spa (Winterizing)

If you do not plan to use your spa during Freezing weather, you will have to winterize it. Failure to winterize your spa will cause irreversible damage (in Freezing temperatures) to the pumps and plumbing lines.

Winterization of your hot tub is easy. Follow the steps in this checklist each time you drain the water from your spa in Freezing temperatures to prevent serious damage from occurring to your hot tub:

- Step 1:** Turn the spa circuit breaker off.
- Step 2:** Open all therapy control valves and all jets.
- Step 3:** Drain your spa. We recommend using a submersible pump. If you don't have a submersible pump, you can attach a garden hose to the external drain fitting. Be sure to run the drain line to an area that can handle the drainage. For faster draining, use both a submersible pump and the drain fitting.
- Step 4:** Remove the cabinet panel in front of the spa's equipment compartment.
- Step 5:** Open the drain fitting to drain any remaining water and leave open afterwards.
- Step 6:** Locate the heater and open the heater unions at both ends by turning counter-clockwise.
- Step 7:** Clear water from the water pump(s) suction and return lines using a canister-type wet vacuum. You MUST use a canister type wet vacuum in order to ensure that the lines are cleared of all remaining water.
- Step 8:** Remove the drain plug(s) from all water pump(s).
- Step 9:** Replace the drain plug(s) after all the water has drained.
- Step 10:** Reconnect the heater unions on the heater at both ends by turning clockwise until they are tight. Make sure O-ring gaskets are sealed properly so as not to pinch O-rings. Do not over-tighten.
- Step 11:** Put the cabinet panel in front of the equipment compartment back on.
- Step 12:** Use a wet vacuum at EACH fitting/jet/suctions to assist in removing any existing water in fittings, water lines and spa shell.
- Step 13:** Sponge out remaining water from spa shell.
- Step 14:** Clean the shell and remove any debris.
- Step 15:** Clean the filter. Vacuum any water out of the bottom of the pressure filter. Store the filter basket and filter element indoors.
- Step 16:** Install the insulated spa cover and check to ensure that rain water and/or snow is not entering the spa through the cover.

Customer Responsibilities

Any spa/hot tub is subject to freezing in cold weather. You must follow these procedures during a power failure or if the hot tub spa is not operating properly in order to prevent your hot tub from freezing.

Preventative Maintenance

During the cold weather season, you should inspect your outdoor hot tub every day to insure it is running properly. If you detect a problem and the temperature is dropping, contact the service department immediately during regular working hours. It is the customer's responsibility to follow the procedures listed above in order to prevent a freeze up.

Note: Spa should be covered with a tarp after closing process.

Troubleshooting - Water Chemistry

Problem	Possible Cause	Solution
Cloudy Water	Dirty Filter High TDS Levels High pH or alkalinity High calcium count Dissolved solids High bacteria level	Clean Filter with Filter cleaner Drain and refill with Fresh water Check and adjust using pH/Alkalinity Down Drain halfWay and refill Add clarifier to your water Shock with sanitizer you currently use
Brown Water	High mineral count Low alkalinity level Low sanitizer level	Add Stain & Scale Test and add pH/Alkalinity Up Test and add sanitizers
Green Water	Algae growth	Shock with sanitizer
Yellow Water	Low pH	Add pH Up
White Scale Deposits	Low sanitizer level	Test and add sanitizer
Excessive Foaming	Soft water High TDS level High contaminant level	Test and add Liquid Calcium Drain & refill the hot tub Add one capful of Foam Away
Waterline Scum Ring	Inadequate Filtration High content of oils	Check and clean Filter(s) Add Natural & Clear
Pitting of Metal Fixtures	Low alkalinity or pH	Check and add pH/Alkalinity Up
Erratic pH Test Results	Low alkalinity Sanitizer level too high Old pH indicator strip	Add pH/Alkalinity Up Remove cover and turn on bubbling system Check expiration date and replace
Musty Odor	Bacteria/algae growth	Shock the water with sanitizers
Eye Irritation	Low pH level Low sanitizer level	Test and add pH/Alkalinity Up Test and add sanitizer
Skin Irritation	Low sanitizer level Sanitizer irritation Water temperature too high Soaking too long Allergic Reaction	Test and add sanitizer After adding sanitizer always wait 20 minutes before entering hot tub Reduce water temperature Soak for shorter intervals See your physician immediately for an allergy test

Control Panel Operation



(For additional information, please see the Special Operating Instructions For your specific hot tub)

TS700 Main Control Panel



Buttons A, B, C, and D may vary depending on your specific spa model. Refer to your Special Operating Instructions for more information.

Pump or Swim Jets (C or D)

Pumps may be 1- or 2- speed. For 2-speed pumps, pressing once puts the pump into high speed, indicated on the LCD by a Fast moving pump icon ; press again for low speed . To turn off, press again (icon disappears from the LCD). If left on, pumps will automatically turn off after 30 minutes. Refer to your Special Operating Instructions for a description of which jets each pump activates.

Light

The underwater light and grab bar lights (if installed on your spa) are turned on or off by pressing the light button. When turned on, the light icon is  displayed on the LCD. In some cases, the light is turned low, medium, high, off. The light button also controls any optional LED lighting if installed on your spa. By turning the LED lights on and off, you can cycle through the various colors programmed into the LED controller (Blue/Green, Purple, Blue, Green/Red, Green, Red, cycling through the colors, strobe effect).

Warm & Cool

The warm & cool buttons are used to change the temperature set-point of the spa. When either button is pressed, "Set Temperature" is displayed on the LCD and the temperature can be adjusted. The minimum set point is 80°, while the maximum is 104°.

Temp

Temperature is adjusted from the swim control panel by pushing the Temp button. The display shows the actual water temperature until the button is pressed. When the button is pressed, the display will show the set temperature. Pressing the button a second time and any successive time will cause the set temperature to increase or decrease depending on what direction was last chosen. If the opposite direction is desired, release the button and let the display revert to the actual water temperature. Repeat the above steps and pressing the button will adjust the temperature in the opposite direction. Each time the panel reverts to the actual water temperature, the Temp button will toggle between increasing and decreasing the set temperature.

Mode/Prog

Repeatedly pressing the mode/prog button will cycle through the available Spa Modes (Standard, Economy, or Sleep - see descriptions below).

Time

Once the time is set, pressing the time button displays the time of day. To set the time, press 'Time' 'Mode/Prog', then use 'Warm' & 'Cool' to select the hour. Once the hour is selected, press 'Mode/Prog' to select the minutes and adjust using 'Warm' & 'Cool'.

Indicator Lights: F1, F2, PL, & TL

F1 & F2 lights indicate programmed Filtration cycles (see Filtration Cycles under Control Panel Features).

PL indicates that the Control Panel is locked. Press 'Time' 'Pump 1' (C) then 'Warm' to lock the panel. To unlock, press 'Time' 'Pump 1' (C) then 'Cool'.

TL indicates that the temperature set-point is locked. Press 'Warm' 'Time' 'Pump 1 (C)' then 'Warm' to lock or unlock the temperature set-point.

Heat Icons

When the temperature bars are alternating between top and bottom, the spa is measuring the water temperature. When the bars progress from top to bottom, the spa water is being heating.

O₃ Ozone Icon

When displayed, the optional Ozonator (if equipped) is activated. If any Control Panel button is pressed, the Ozone Icon will turn off and the Ozonator deactivated for 30 minutes after any button press. However, if the optional ThermOzone system is installed it is always functioning regardless of the icon status.

Mode Icons

Either the Standard, Economy, Standard-in-Economy, or Sleep icon will be displayed depending on the mode selected. See the descriptions below.

Spa Modes

Standard Mode constantly maintains the set temperature, assuming too many pumps aren't running (see Electrical Service under Control Panel Features). Heating will occur until the water reaches the next highest degree above the temperature set-point. The Standard icon will be displayed unless the mode is changed.

Economy Mode allows the spa to heat only during the preset Filtration cycles. In spas with continuous circulation, F1 & F2 Economy Cycle times must be set. Heating will occur until the water reaches the next highest degree above the temperature set-point. The Economy icon will be displayed unless the mode is changed. Pressing the 'Pump 1' (C) button will change the mode to Standard and display the Economy-in-Standard icon. The spa will automatically revert to Economy mode after one hour (or instantly if you press 'Mode/Prog').

Sleep Mode heats the spa to within 20° of the temperature set-point, but only during Filtration cycles. The Sleep icon will be displayed unless the mode is changed.

Additional Control Panels - supplied on some spa models

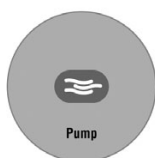

Auxiliary Pump

If equipped on your spa, Auxiliary Pump buttons control additional pumps in your spa. Refer to your Special Operating Instructions for details.



Wave Lounge Pump & Valve

If your spa is equipped with a Wave Lounge, these buttons control the Wave Lounge Pump and Wave Lounge Valve. The Wave Lounge Pump is a 1 speed pump. Pressing once puts the pump into high speed. To turn off, press again. If left on, the Pump will automatically turn off after 30 minutes. Once the Wave Lounge Pump is activated, press the Wave Lounge Start/Stop button to begin the sequencing Wave Lounge action. Press again to stop the valve and isolate specific jets. Refer to your Special Operating Instructions for a description of which jets are controlled.



Swim Control

If installed, allows control from the swim end of your spa. Swim Jets 1 and Swim Jets 2 operate the swim pumps as described above. Press the "Temp" button to display the set temperature or change the set temperature as described above.

Control Panel Features

Power-Up Sequence

When power to the spa is turned on, the Main Control Panel will display a series of diagnostic numbers and/or letters. When it displays "Pr", it has finished initiation and enters into Prime Mode. Prime Mode will last for 4-5 minutes before automatically entering Run Mode. Run Mode can be entered earlier by pressing either the 'Warm' or 'Cool' button.

Circulation Pump Operation

For spas equipped with a circulation pump, Filtration and heating are controlled based on the mode selected and electrical service in conjunction with the circulation pump.

Circulation Pump

The Circulation Pump will run 24 hours a day, 7 days a week to efficiently and effectively filter your spa water. However, if the spa temperature exceeds the set-point by 3° the circulation pump will automatically turn off. It will only turn back on during the preset Filtration cycles or after the water temperature is within or below 3° of the set-point. Any time the circulation pump is running, your spa will be filtering water (unless your filters are too dirty to permit water to pass through them).

Filtration Cycles

Filtration Cycles are set at the Factory to occur From 8am-10am and 8pm-10pm. To change the Filtration cycle start and end times, press 'Time' 'Mode' 'Mode' 'Mode'. Then use the 'Warm' and 'Cool' buttons to adjust the start and end times For both Filtration cycles. Press 'Mode' to select the chosen time and eventually return to normal operation.

Electrical Service

The Electrical Service determines how many pumps can run in conjunction with the heater. If the dedicated GFCI circuit was installed with a smaller breaker than the recommended size (typically 60 amps), your heater will automatically shut off to avoid tripping your circuit breaker if too many pumps are activated. Heating will automatically turn back on after pumps have been shut off. All of this may occur even though the circulation pump continues to run – when the heater is on, progressing bars will be indicated from the bottom to the top of the heater icon.

Standby Mode

Use the Standby Mode if you need to temporarily shut off the circulation pump (to aid in removing Filters). To enter Standby Mode press 'Cool', then 'Pump 2' (D) or 'Swim Pump 2'. To resume normal operation, press any Control Panel button or wait approximately five minutes.

Clean-up Cycle

The Clean-up Cycle is a feature that automatically turns on a pump 30 minutes after it was last turned off or timed out. The pump will run for approximately 30 seconds to move water through the system to help maintain clear water.

Purge Cycle

The Purge Cycle is intended to keep the spa as clean as possible by flushing all jet lines every 12 hours. All pumps will turn on for 5 minutes. Purge cycles occur at the beginning of each Filter Cycle.

Freeze Protection

Freeze Protection is activated if the temperature sensors in the heater detect a drop to 44°. All pumps activate automatically and remain on until 4 minutes after the sensors detect that the spa temperature has risen to 45° or higher. During this time "ICE" will be displayed and no button presses will be recognized until the spa water has reached 45°.

Common Diagnostic Messages

Troubleshooting Code	Meaning	Action
OHH	Overheat - The spa has shut down. One of the sensors has detected 118°F (approximately 47.8°C) at the heater:	DO NOT ENTER THE WATER. Remove the spa cover and allow water to cool. Once the heater has cooled, reset by pushing any button. IF spa does not reset, shut off the power to the spa and call service or your local dealer.
OHS	Overheat - The spa has shut down. One of the sensors has detected 110°F (approximately 43.3°C) at the heater:	DO NOT ENTER WATER. Remove the spa cover and allow water to cool. Once the spa reaches 107°F, (approximately 41.7°C) the spa should automatically reset. IF spa does not reset call service or your local dealer.
ICE	Potential Freeze condition exists.	No Action required. The pumps and the blower will automatically activate regardless of spa status.
SnA	Spa has shut down. The sensor that is plugged into sensor "A" Jack is not working.	IF the problem persists, contact service or your local dealer (this may appear temporarily in an overheat situation and disappear when the heater cools.)
SnB	Spa has shut down. The sensor that is plugged into sensor "B" Jack is not working.	IF the problem persists, contact service or your local dealer (this may appear temporarily in an overheat situation and disappear when the heater cools.)
SnS	Sensors are out of balance. IF this is alternating with the temperature, it may be a temporary condition. IF the display shows only this message (periodic blinking) the spa has shut down.	IF problem persists, contact service or local dealer.
HFL	A substantial difference between the temperature sensors was detected. This could indicate a flow problem.	Check the water level in spa. Add water if necessary. IF the water level is okay, make sure the pumps have been primed. IF the problem persists, contact your dealer or service organization.
LF	Persistent low flow problems. (Displays on the fifth occurrence of the "HFL" message within 24 hrs.) Heater is shut down, but other spa functions continue to run normally.	Follow actions required for HFL message. Heating capacity of the spa will not reset automatically; you may press any button to reset.

Troubleshooting - Mechanical Systems

Problem	Possible Cause	Solution
Pump(s) will not start	"T" valve(s) not open	Check both "T" valves on all pumps. Be sure valve is open by pulling up on handle until detent click is felt. Detent prevents valve from vibrating shut.
	Pump(s) not primed	Open suction side pump union until water begins to trickle.
	Frozen pump impeller	Use hairdryer to warm pump volute in area of drain plug. Keep hairdryer 6 inches from volute and heat using a side to side motion. Do not allow volute to become hot to the touch.
Spa Pump(s) surging	Air being pulled through	If spa is equipped with a Skimmer basket, it should be all the way down. Door should move freely.
	Water level low	Fill spa to recommended level.
No Water Pressure in Sections of the Spa	Water not being Diverted Correctly	Turn diverting valve to divert water.
	Pump not on	Turn on correct pump. Refer to "pump(s) will not start" (above)
	Jets not Open	Turn jets counter-clockwise to open.
Spa Not Heating (Heat Icon On)	1. Pump(s) not on	1. Refer to "pump(s) will not start" (above)
	2. Closed T Valve	2. Lift T Valve up so it is all the way open to allow water to go through it.
	3. Spa may be in Economy Mode (Heater Icon Not On)	3. Put spa in STD mode. See special operating instructions.
	4. Dirty Filters	4. Replace filters with clean or new filters.
	5. Pump Malfunction	5. Repair or replace pump.
	6. Inadequate Water Level	6. Add water until it reaches proper level.
	7. Heater Malfunction	7. Replace heater.
Circulation Pump Not Working	1. Water Temperature is 3° or more above set temperature.	1. Open cover and wait for spa to cool. If spa is equipped with a blower, turn it on.

Note: All spas come with special operating instructions. These may help with troubleshooting. Special Operating Instructions may be downloaded at www.thermospas.com/service.

Problem	Possible Cause	Solution
Flashing O3 on Control Panel Spas with Ozonators Spas with out Ozonators	Ozone working Irrelevant	No Action required Call customer care or service to purchase
Dry/Dr4 - Inadequate water detected in heater. (Displayed on 3rd occurrence of "dr" message) Spa is shut down.	1. Closed T-Valves 2. Loss of prime 3. Circulation Pump MalFunction 4. Dirty Filters/old Filters	1. Open T-Valve around heater by lifting handle all the way up. 2. Prime circulation pump while pump is on by losing union. 3. Call service to order a new pump or to set up a service appointment. 4. Remove and clean Filters or replace with new ones.
OHH (Overheat) The spa has shut down. One of the sensors has detected that the spa water is 110° F (Approximately 43.3° C)	1. Partially closed T-Valve 2. Outside temperature is at or around 110°F/43.3°C 3. Dirty Filters/old Filters	1. Lift T-Valve all the way up. 2. Remove some hot water and add cool water. Turn blower on(if equipped), and remove the cover. 3. Remove and clean Filters, replace with new ones.
Breaker keeps Tripping or Breaker will not Reset	Improperly wired ground Electronic component needs repair	Contact your electrician Contact ThermoSpas Service Department
Spa Leaks	Loose union Drain Fitting open Leaking Barb Fitting Leaking Glue Fitting Improperly Seated Gasket	Check and tighten all unions Close drain Fitting Check hose to barb Connection. Clamp hose if required, Call ThermoSpas For service. Call ThermoSpas For service Check and re-seat O-ring

FAQs

Q: What happens if I don't change my ThermoClear cartridge in four months?

A: The ThermoClear cartridge will start to become ineffective after four months. So, along with having water that could potentially have a high TDS reading, prohibiting chemicals from being effective, you will have no method of sanitizing your water leading to potential health risks.

Q: Which is better to use on a weekly basis with ThermoClear: Spa Activator or Chlorine?

A: If you are not in any way allergic to Chlorine, then we strongly recommend using it. Chlorine has a higher ORP rating (oxidation reduction potential) which is the measure of oxidizing power. The oxidizing power is the ability to burn away organic matter. However, you must continue to use the Spa Activator each time you use your hot tub. Please refer to the comparison chart on page 22 for a comparison of the various sanitization methods.

Q: What should I do if my dog or cat jumps into the hot tub?

A: Unfortunately animals in hot water produce over 50 times more bacteria than humans, because of this you have to drain and refill your spa.

Q: What happens if I put too much sanitizer into the water?

A: Too much Spa Activator can cause the skin to itch and potentially produce a skin rash. Over-shocking your water could potentially damage your hot tub cover, and this would not be covered in the warranty. Also, an excess of sanitizer might not produce any reading on your test strip because you have gone beyond its reading capabilities. This has led people to add more Spa Activator which can make matters worse.

Q: How can I reduce my sanitizer level?

A: There are two simple methods to reduce sanitizer levels:

1. Drain 1/2 of your water and refill the hot tub; or
2. Remove the cover and turn all jets and open all Therapy Control valves. Monitor the sanitizer level with test strips until the recommended level is achieved.

Q: Why does ThermoSpas recommend against the use of Biguanide or copper based algaecides in my spa?

A:

1. Biguanide and copper based algaecide products may attack critical parts of the pumps and plumbing leading to premature failure of the spa.
2. Chlorine may not be used with Biguanide based sanitizers. Over time certain bacteria will develop a tolerance to Biguanide. When this occurs chlorination of the spa is the most effective means of destroying these bacteria. At this time, it is common for most spas to switch to a chlorine and/or bromine sanitizer.

Q: Can I change sanitizers?

A: The use of ThermoClear and Chlorine can be interchanged in the same spa water. All other sanitizers require the draining of the hot tub. We recommend the use of ThermoSpas' Jet Line Cleaner for cleaning out the lines.

Q: Why can't I use swimming pool chemicals?

A: A hot tub is dramatically different from a swimming pool because you are working with water that is both heated and also aerated. In addition, the chemical make-up of swimming pool chemicals is usually quite different from that of hot tub chemicals. One example is that swimming pool chemicals are not buffered so they can create havoc on the pH level of your hot tub water.

Q: Why are my pillows/headrests discolored or bleached out?

A: Headrests that are constantly submerged in spa water that is not properly treated with chemicals may discolor. However, even if you have been performing your water maintenance faithfully and correctly, the pillows will still naturally discolor over time. ThermoSpas does not provide warranty coverage for bleaching or discoloration of spa pillows.

Q: I have done everything I could and there is still something wrong with my water.

A: ThermoSpas offers free computerized testing of your water. If you reach the point of having no luck with keeping your water in balance, and have tried draining and refilling your tub, you can send us a sample of your hot tub water for analysis. Please contact our customer care department.

Q: What can I do if the pH in my spa is high (over 8.0) and will not come down?

A: Follow the steps below.

1. Turn on all pumps and add ThermoSpas pH Down. Wait 15 minutes and retest the pH.
2. If the pH is still out of the acceptable range add pH down and retest after 15 minutes. Pumps should continue to run.

3. If the pH reading is still high, Step 2 may be repeated an additional two times.
4. Upon completion of Step 3, if the pH is still high, contact ThermoSpas Customer Care Dept.

Q: Do spas with Ozonators require less chemicals?

A: Yes. If your hot tub includes an Ozonator, you can reduce your use of sanitizer. For example, hot tubs with Ozonators require a bromine reading of only 1 to 3 ppm instead of 3-5 ppm without an ozonator.

Q: Why do I need any chemicals if Ozonators work so well?

A: Ozone is a powerful oxidizer and is considered to be 25 times more effective and works 100 times faster than traditional sanitizers like Chlorine or Bromine. However, ozone only lasts about 20 minutes in a hot tub when the filtration pump shuts off. There are many contaminants (i.e. algae, ammonia, nitrogen laden compounds, and bather wastes) that are not controlled by ozone. Also, Ozonators have no effect on reducing the use of any other chemical but sanitizers.

Q: How do you prime a pump?

A: The best way to prime a pump is to put pump into high speed and loosen pump union just a little bit to let the air escape from pump then tighten the union back up.

Q: What is dr?

A: dr means there is inadequate water flow detected in the heater and on 3rd occurrence of this control panel will display dr4 or dry. RESOLVE: Prime circulation pump and make sure all the valves are up before contacting service for further troubleshooting.

Q: How come 24 hour circulation pump turns on for 3 minutes then shuts off?

A: With the new addition of the 24 hour circulation pump they are set to turn on for 3 minutes then shut off once the spa goes 3° over the desired set temperature to eliminate heat gain from pump.

Q: How do I change my filters if my circulation pump runs for 24 hours?

A: On some models of ThermoSpas it is almost impossible to change the filters while the pump is on so the spa must be put into standby mode by pressing Cool, then Pump 2 (D), or by shutting off power to the spa.

Q: What does O3 mean on the control panel?

A: O3 simply means if you have an ozonator in your spa it is on if you do not have one this is an option please call the service department if you wish to order one or to have one installed.

ThermOzone Note: If O3 doesn't show up on your control panel this doesn't mean your ThermOzone isn't working O3 shows up periodically and ozonator works even when light isn't on.

Q: I am going away on vacation, should I winterize?

A: Winterizing your spa while you are on vacation is not only smart but it could save you on operating costs. You won't have to have someone check it every 24hrs. If the power goes out or spa freezes this will also eliminate any freeze damage which isn't covered under any warranty. *NOTE: It is the customers responsibility to keep the spa from freezing.*

Q: Why is my pump always running?

A: If your spa has a circulation pump it is set to run 24/7, unless the spa temperature goes 3 degrees above the set temperature.

Q: How do I troubleshoot an instantly tripping breaker?

A: a. On new spas, call your electrician to verify breaker wiring. b. On established spas, the proper way to troubleshoot is first turn the GFCI breaker off. Access spa pac and label and unplug all components except for light: all water pumps, blowers, and ozonator if spa has one. Then turn the GFCI breaker back on. If breaker does not hold the only components that are still connected is the heater since heater wires are inside spa pac. If breaker does hold, one at a time replug in components and which ever one is failing will trip breaker when you plug it in. At this point the second, third, fourth pump can be left unplugged. Also if a blower or an ozonator is causing the problem, they can be left unplugged. Only the spa's heater and circulation pump are necessary to maintain heat and filter cycle.

Q: I have no pressure to one of my seats, what is the problem?

A: a. Ensure the correct jet/pump button is on. b. Try your top side diverter valve. c. Your jets may be in the closed position. Most of the jets in your spa have an outer ring that turns to the left and right. This will open or close the jets.

Q: My pump isn't working properly and it doesn't seem to be pushing any water at all, what can I do?

A: a. Open your panel and find your pump. Chances are a gate valve might be closed, which will shut the pump off. Open the valve by lifting the handle. b. Your pump may need to be primed. Open the union connection slightly to bleed the air out of the line.

- Q: I need a service appointment, but I'm only available after 5PM. Is there any way that you can come later?**
- A:** If your spa and circuit breaker are outdoors, you don't need to be home. We can easily set up an appointment and you will not need to lose time at work. Our technicians work to be sure that all of their scheduled stops are completed to satisfaction every day, and that includes scheduling time of their stops.
- Q: I have a brand new hot tub and it is leaking. I need a service man right away.**
- A:** There are a few things we will ask you to do. Describe that area of the spa where the leak seems to be coming from. Open one of the panels in that area and check your pumps union connections. If you have a loose union, simply tighten the connection and the leak should stop. This is a part of your spa start up and is the responsibility of all of our customers to make sure that this is done.

Glossary

Activator (Potassium Peroxymonosulfate) -

Also known as non-chlorine shock, it is a strong oxidizer capable of eliminating contaminants from your spa. It is a non-chlorine chemical compound often used for shock treatments in spas and pools. It is very popular for use in mineral purification systems.

Algae -

Over 20,000 species known! Algae may form on your spa surfaces or it may bloom in suspension. We typically know algae to be green, but it may also be yellow (mustard algae), black, blue-green or any shade in between. It may form separate spots, or seem to grow in sheets. Pink algae, is not algae at all, but a form of bacteria. Algae are living, breathing organisms that need warmth, sunlight and CO2 to thrive.

Bather Load -

The number of individuals using a pool or spa in a 24 hour period. This is the primary source of bacterial and organic contamination.

Biguanide -

A chlorine-free pool and spa sanitizer. The biguanide system is a 3-part system. ThermoSpas does not recommend the use of biguanide products in our spas.

Biofilm -

A thin usually resistant layer of microorganisms (such as bacteria) that form on and coat various surfaces of your spa, like the pipes and catheters in your plumbing.

Bromine Liquid Salts -

In 2-Part Bromide, a compound called sodium bromide (Liquid Salts) is first introduced into the water. Sodium bromide is NOT a sanitizer by itself. To work as a sanitizer the sodium bromide needs an oxidizer, such as peroxy-monosulfate, to activate it. The addition of an oxidizer sets the bromide in motion, turning the bromide into the killing form of bromine. After destroying bacteria, algae and other organisms, it can become bromide once again. The oxidizer shocks the water and off-gases the physical waste. Adding additional oxidizer can start the process all over, converting bromide into a sanitizer. This cycle can occur repeatedly.

Bromine Liquid Salts Advantages

- Does not create an offensive odor
- Is pH neutral
- If tub is not in use, no chemicals need to be added for up to 1 week
- Considered the most effective Bromine system on the market

Disadvantages

- Requires the use and knowledge of two separate chemicals
- Cannot be used with ThermoClear

Bromine Tablets -

Bromine Tablets are a combination of 70% bromide and 30% chlorine. Tablets are inserted into a dispenser that floats in the water providing continuous coverage. As the tablet dissolves, it releases the bromide and chlorine. The two work together immediately to produce bromine, the active chemical used in sanitization.

Advantages

- Easy to use
- Scent of chlorine is reduced

Disadvantages

- Bromine can potentially bleach out the shell's surface
- Odor of 30% chlorine still exists
- Tablets are not pH neutral
- Cannot be used with ThermoClear

Calcium -

One of the principal elements making up the earth's crust; its compounds, when dissolved, make the water hard. The presence of calcium in water is a factor contributing to the formation of scale.

Copper -

Copper in water is a common problem in many households. Copper is present due to the corrosion of plumbing materials from acidic (low pH) or aggressive water (low TDS). Common problems associated with copper corrosion are leaks in the plumbing system or blue-green staining. High copper content can also cause some health concerns by affecting the stomach and intestines. The EPA has set a maximum contaminant level of 1.3 ppm.

Cyanuric Acid -

A granular chemical added to the spa water which provides a shield to chlorine for protection from UV radiation, which disrupts the molecule, destroying its sanitizing ability.

Disinfect -

To kill living organisms on contact. The difference between a disinfectant and a sanitizer is the "kill time": a disinfectant kills 99.9% of living organisms instantly. Chlorine and bromine are the only two sanitizers classified as disinfectants.

Enzymes -

Used in spa formulations designed to break down and digest oils similar to the way enzymes are used in oil spill clean-up efforts.

Fill Water -

Used in filling or adding to the water level. Whether from the hose or from a well, your fill water brings its own chemical make up and water balance (or lack thereof).

Filter -

A device used to remove particles suspended in the water by pumping water through a porous substance or material.

Filter Cleaner -

A deep cleaning filter soak that includes a releasing agent to relax the filter media and allow dirt and grime to be dissolved and cleaned.

Filter Media -

A pleated, porous synthetic fabric in filter cartridges, used to trap foreign matter. Filter cartridges must be cleaned regularly with filter cleaning compounds.

Foam Away -

Excessive foaming is typically caused by swimwear used when bathing in a spa or pool. Using a capful of foam away instantly reduces foam and will allow detergents to be filtered out of your water.

Foaming -

A term used to describe surface foam on your water, especially in spas/hot tubs. Foaming is caused by high TDS levels working in combination with soft water and oils. Certain low grade algaecides can foam when added to pool or spa. Use enzymes for foam control.

Hot Tub Folliculitis -

A skin condition often seen where spa sanitation is at fault. See Pseudomonas.

Iron -

An element often found discolored in ground water (in the form of ferrous iron) in concentrations usually ranging from zero to 10 ppm (mg/L). It is objectionable in water supplies because it can affect water taste and can cause unsightly colors when iron reacts with tannins in beverages such as coffee and tea. Iron causes

staining after oxidation and precipitation, as Ferric hydroxide (yellow, brown, and red on clothing, dishes, fixtures, and bathroom tile). Iron can also be found in a bacterial form which will appear as black or brown slime and can affect the odor of your water. Iron is a common water problem throughout the United States, it can be found in well water and municipal water. The EPA has set a maximum level for iron of 0.3 ppm in water; iron concentrations at this level or higher can cause staining.

Jet Line Cleaner -

This anti-bacterial cleaner is added to spa water prior to draining and refilling. Left in the spa for an extended period (3 – 24 hrs), this cleaner will break down accumulated biofilm in spa plumbing. This product can also be used in jetted bath tubs.

Manganese -

An element sometimes found in ground water, usually with dissolved iron but in lower concentrations. Manganese is a typical natural occurring mineral found in municipal and well water. Manganese affects the taste and the color of water. Manganese can also cause staining of clothes and dishware and black stains and other problems similar to iron. The EPA has determined that concentrations greater than 0.05 ppm can cause these aesthetic problems.

Media -

The selected materials in a filter that form the barrier to the passage of certain suspended solids or dissolved molecules.

Mineral Purification System (ThermoClear Cartridge) -

Mineral cartridges are placed in your filter core and release silver and copper ions into the spa water. These ions kill bacteria and viruses. Activator must be used to oxidize the organic material the silver and copper ions have killed. Very low levels of chlorine (.5ppm) are recommended as a safety precaution.

Mineral Sanitizer -

A sanitation system that releases very low levels of silver ions into the water which assist in controlling bacteria 24 hours per day. ThermoClear cartridges trap bacteria that approach its surface. Activator then assists in cremating (oxidizing) the dead bacteria within the cartridge. The cartridge should be placed in the center of your spa filter.

Multi Purpose Cleaner -

An enzymatic cleanser used to clean scum lines and mineral deposits off the shell and cabinet surface. This cleanser is pH neutral and will not affect water chemistry. It should be used on a weekly basis and is also a good cleaner to prep your shell for a coating of Acrylic Gloss.

Natural & Clear -

A natural enzyme used to devour oils and organic material (skin, hair etc.) left in the spa by bathers that cannot be burned off by oxidizers, sanitizers or disinfectants used in spa sanitation.

Oxidize -

To destroy and burn off all the dirt and inorganic or dead organic matter in the water. A sanitizer can oxidize materials such as ammonia, nitrogen-containing contaminants and swimmer waste.

Ozone -

"Active oxygen", nature's special molecule (an ozone molecule consists of three oxygen atoms). It is created in nature by the combination of oxygen in the air, and ultraviolet rays or by the electrical discharge during a lightning storm. Ozone is a natural purifier (meaning no harmful chemical by-products are created during purification), it has a clean, fresh scent noticed after a rainstorm. Ozone is the most powerful oxidizer that can be safely used in a swimming pool or spa and is the alternative water purifier to traditional pool/spa chemicals such as chlorine and bromine. Because ozone is a disinfectant it will allow you to reduce your sanitizer usage. It is always recommended that a 1 – 3ppm sanitizer level be maintained with any ozone system.

pH -

The scale of relative acidity. Measurements are expressed in numbers from 0 - 14, with 7.0 being neutral. Acceptable spa ranges are 7.2 – 7.8

pH Down - Used to decrease both the pH and Alkalinity levels of your spa water

pH Up - Used to increase both the pH and Alkalinity levels of your spa water.

PPM -

Abbreviation for 'parts per million', the unit of measurement used in chemical testing which indicates the parts by weight in relation to one million parts by weight of water.

Protection Plus -

A high powered metal sequestering agent used to keep mineral and metal deposits from forming on the shell. This product also adds a clarifier to screen the water of fine particulate unable to be caught by your filter.

Pseudomonas -

Pseudomonas bacteria can cause Hot Tub Folliculitis, a condition often seen where spa sanitation is at fault. The most common symptom is an itchy rash or small reddish bumps, sometimes confused with bug bites.

R-Value -

The measure of resistance to the flow of heat through a given thickness of a material (as insulation) with higher numbers indicating better insulating properties. In spa covers, a higher R-Value will save energy costs.

Safety Cover -

A spa cover which meets strict ASTM standards for strength, construction, and anchoring, which reduces the drowning risk to small children. (Our covers are built to the ASTM safety standard). Not all hot tub covers on the market meet this important rating.

Sanitize -

To kill all bacteria, algae, disease-causing organisms, and any other uninvited guests. One important job of any sanitizer is to provide a sanitizer residual, a level of sanitizer that hangs around (resides) in the water for some period of time to destroy any living organisms as they are introduced into the hot tub.

Scale -

A substance that forms on surfaces in contact with water when the calcium hardness, pH or total alkalinity levels are too high. Scale may appear as grey, white or dark streaks. It may also appear as a hard crust around the tile.

Sequestering Agent -

A sequestering agent ties-up minerals tightly in solution, preventing their precipitation, which colors the water and/or stains the spa.

Shock -

This word is used two ways in the Pool and Spa industry. As a noun it loosely describes the products used in shocking, such as hypochlorites, potassium peroxydisulfate or hydrogen peroxide. As a verb it describes the act of bringing the sanitizer level up so high that breakpoint chlorination is reached. When breakpoint is reached, a "shock" or perhaps a "lightning bolt" is a better analogy, is sent through the water, tearing apart molecules and slashing through cell walls. Ultimate purification, man.

Skimmer -

A surface skimmer is a plumbing fitting set at water level, containing a weir mechanism and a debris basket. The skimmer is part of the suction side circulation system.

Skimmer Basket -

Beneath the lid, the basket strains debris, as the first line of defense in filtering the water.

Sodium Bicarbonate (pH/Alk Up) -

Used to raise Total Alkalinity levels.

Sodium Bisulfate (pH/Alk Down) -

Used to counteract a scaling condition by lowering pH and/or alkalinity.

SOI -

Abbreviation for Special Operating Instructions. This is the documentation you received with your spa describes the features of your custom hot tub specifically and in more detail than this manual.

Spa Cover Conditioner -

This product is specially formulated for vinyl spa covers. It will not dry out vinyl as automobile cleaners might. Spa Cover Conditioner will deep clean your cover while providing a bright, durable shine that will inhibit harmful UV rays.

Spa Fragrance -

Special perfumes designed to enhance the hot tub experience and overcome chemical odors. These are designed for spas, and will not alter water balance or clog filters.

Stain & Scale -

A metal sequestering agent used to keep mineral and metal deposits from forming on spa equipment.

Superchlorination -

Applying 7 - 10 times the normal amounts of chlorine to the spa as an added "boost" for contaminant removal. Some refer to superchlorinating as being less than shocking, in that breakpoint thresholds are not reached, or the terms may be used synonymously.

Test Strips -

Easy-to-use dip strips for measuring the pH, total alkalinity and sanitizer levels of spa water. Strips are also available for testing water hardness and Total Dissolved Solid levels.

ThermoGloss -

This product is an acrylic gloss that provides a tough coating to protect your shell from scratches and scale build up. Designed for hot water environments, this product will not break down and cause problems in spa water.

ThermOzone -

The only automatic ozonator with an EPA approved, built-in de-gasser tank that eliminates all offensive and potentially dangerous gases. This makes it safe to use while you're in your hot tub, and it is the only one recommended for indoor hot tub installations. ThermOzone produces eight times more ozone per hour than other ozonators, and it minimizes the creation of excess "off-gas" by using a Mixing Degas Vessel (MDV) to safely mix ozone into the water. Ozone only disinfects water while it is in contact with it, and the MDV provides an area where the ozone contacts the water for a longer period of time, making it more effective. If any excess off-gas is produced, ThermOzone eliminates it with a charcoal/carbon canister, safely converting the off-gas back into oxygen.

Total Alkalinity -

The ability of the spa water to resist changes in pH. The "buffering" capacity of the water. Additions of Sodium Bicarbonate will increase the levels, expressed in ppm. Additions of Sodium Bisulfate decrease Alkalinity levels. Acceptable measurements range from 80 – 120.

Total Dissolved Solids (TDS) -

A measurement of the total amount of minerals, residue, and other particles that cannot be oxidized from the water and remain. When water evaporates, dissolved salts, minerals, etc. are left behind. These levels of dissolved solids increase in the spa as water evaporates over time. Tubs that have a high TDS level means that the water is over saturated and cannot receive any more chemicals. TDS should never be higher than 3000ppm. The water needs to be drained at this point, and the tub cleaned and refilled.

Water Hardness -

A characteristic of natural water due to the presence of dissolved calcium and magnesium; water hardness is responsible for most scale formations. Hardness is usually expressed in parts per million. The ideal range for Water Hardness is 100-250ppm, though 250-400 is acceptable. Soft water in a spa will cause instant foaming and staining of water and shell. Water with low hardness is highly corrosive, causing significant damage to any metal. Water will dissolve other minerals rapidly until it gets to saturation point. Large, coarse soft-water scale will form as a result. Hardness levels can be brought up by using Liquid Calcium. Water with high hardness levels can cause excessive scale formation. Water may also become cloudy or slightly discolored. Hardness levels can only be reduced by using an in-home water treatment system or removing water from the tub, and adding distilled water.

Weir -

The device in a skimmer that controls the amount of water coming into the skimmer, and keeps debris inside, otherwise known as a "flapper-gate".

Winterizing -

The procedure of preparing spas for freezing weather, in cold climates when the spa will not be operated. May include draining and cleaning the shell, and opening connections to release water from plumbing and heaters. Most people continue to heat and operate their spas in winter; for them, winterizing is not necessary if appropriate measures are taken to prevent freeze-up.

Notes

The logo for ThermoSpas, featuring the brand name in a stylized, italicized font. The 'T' is large and bold, and the 'S' has a distinctive shape. A registered trademark symbol (®) is located to the upper right of the 's'.

Luxurious Hot Tubs Made Affordable.

155 East Street | Wallingford, CT 06492
www.thermospas.com

SAVE THESE INSTRUCTIONS