



**WHITEWATER / PERFORMANCE
TROUBLESHOOTING GUIDE**

Tools & Parts

- *Tools Required*
- *Parts Required*

Error Messages

- *3 Flashing Dots*
- *Pressure or Flow Switch Not Activated*
- *Pressure or Flow Switch Activated*
- *Temperature Sensor*
- *Over Temperature*
- *Freeze Protection*

Programming

- *Low Level Programming*

Identified Problems

- *Nothing Works!*
- *Spa Is Not Heating*
- *Pump 1 Does Not Work!*
- *Pump 2 Does Not Work!*
- *Blower Does Not Work!*
- *Ozonator Does Not Work!*
- *Spa Light Does Not Work!*
- *Fiber Optic Does Not Work!*
- *Spaside Does Not Work!*

This Trouble Shooting Manual has been designed for easy simple step-by-step problem solving and fault isolation.

It is important to identify all of the possible causes of the problem before making a final diagnosis. What you see at first is usually a symptom of the problem, not necessarily the problem itself.

Read the entire trouble shooting procedure related to what you are testing for prior to performing the test. This will give you a clearer overall view and help to avoid a misdiagnosis.

Tools Required

- Phillips & flat screwdriver
- Pliers
- 11/32" nut driver
- 1/4" open end wrench
- 3/8" open end wrench
- Jumper cable
- Multi-meter and clamp-on Ammeter
- Accurate thermometer
- GFCI tester (optional)



Parts Required

- Spaside control
- Temperature sensor
- Hi-Limit sensor
- Fuses
- Printed circuit board



Pre-Test

Prior to the service call, have the homeowner check the following:

- Make sure spa is filled to the water level recommended.
- Insure that all water shut off valves are open and not vibrating closed.
- Assure that there is no obstruction to the pump suction fittings.
- Adjust diverter valves and/or jets to allow adequate back pressure to heater assembly.
- If a Pressure switch error is reported: Remove the filter and operate the system. If the error goes away, a filter cleaning is required. Let the customer know that the filter may never **look dirty**, we are dealing with oils, lotions etc... Use an appropriate filter-cleaning agent.
- Get all of the information required off of the data label.

If 3 Flashing dots appear below the temperature display, this indicates an error condition. To properly identify the problem, perform the following test:

- The first step is to verify if the LED error indicator (located on the printed circuit board, below the spaside plug connector) is illuminated.
- If the LED error indicator is illuminated, this indicates an Over Temperature condition. **(Continue to the Over Temperature section of this manual)**
- If the LED error indicator is not illuminated, turn the Pump(s) off by either pressing the Pump (1or2) Key or by lowering the set temperature below the actual spa water temperature (there is a 20-second cool down cycle once the heater has been turned off prior to the pump shutting off).
- If the 3 flashing dots are still present below the temperature display, this indicates that the pressure switch is activated while there is no water flowing through the heater. **(Continue to the Pressure Switch Activated section of this manual)**
- If the 3 flashing dots are not present below the temperature display, this indicates that the pressure switch was not activated while there was water flowing through the heater. **(Continue to the Pressure Switch Not Activated section of this manual)**

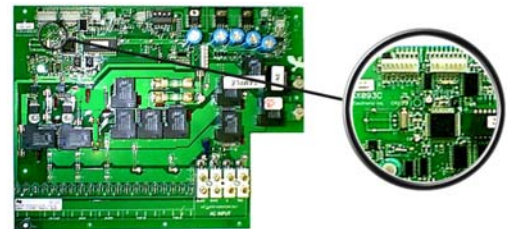

If **3 Flashing dots** appear below the temperature display, this indicates an error condition. To properly identify the problem, perform the following test:

Note that there must be enough water in the spa for it to be used normally. This error indication can occur when the spa filter is dirty or when something limits the flow of water in the pipe.

When this error indication is displayed, the heater is shut off.

Power can remain on while the following steps are performed.

- A system utilizing a flow switch showing **3 Flashing Dots** below the displayed temperature will not be corrected by installing a pressure switch.
- A system utilizing a pressure switch showing **3 Flashing Dots** below the displayed temperature will not be corrected by replacing the pressure switch.
- Verify that the pump is working. If the pump is not functioning properly, refer to the pump section of this manual.
- Make sure to clean the filter and to check for air locks, closed valves or anything that could restrict the flow of water.
- Verify that the pressure or flow switch cable is properly connected to the pressure or flow switch and the printed circuit board.
- Lower the Set Temperature to **60°F** by pressing and holding the Down Arrow key. The pump will turn off after a 20-second cool down. If the 3 Flashing Dots are still present this refers to the Pressure or Flow Switch Activated section of this manual.
- If the 3 Flashing Dots went away, the pressure or flow was not activated while the pump was running.
- Readjust the pressure or flow switch. If it cannot be adjusted, replace the pressure or flow switch.
- If the error indication is still present, replace the printed circuit board.

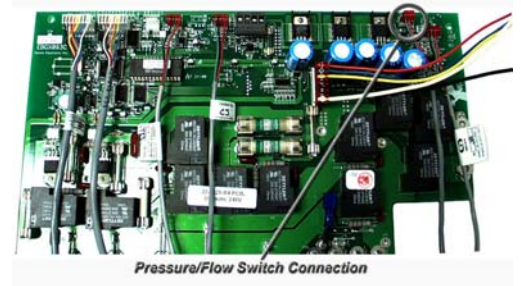
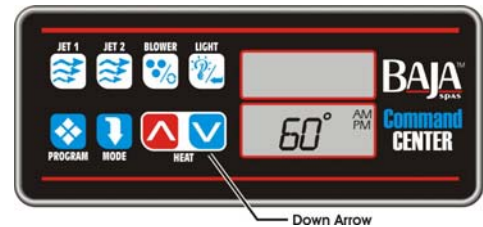

If the **3 Flashing Dots** appear below the temperature display while the pump is turned off this is an indication that the pressure or flow switch is activated. Perform the following tests:

Power can remain On while the following steps are performed.

- Disconnect the pressure or flow switch cable from the printed circuit board.
- If the 3 Flashing Dots do not go away, replace the printed circuit board.



Pressure Switch Adjustment

- Fill spa to maximum water level.
- Apply power and operate jets on high speed to establish full water flow throughout the system.
- Turn **OFF** all power to the system.
- Remove the wires from the pressure switch. Place an Ohmmeter across both terminals to verify that the circuit is "open".
- Rotate the pressure switch adjustment screw **counter-clockwise** until the ohmmeter indicates a "closed" circuit.
- Rotate the pressure switch adjustment screw **clockwise** until the ohmmeter just indicates an "open" circuit.
- Replace wires on pressure switch, apply power and operate spa as normal.

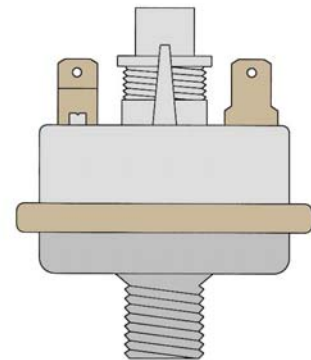
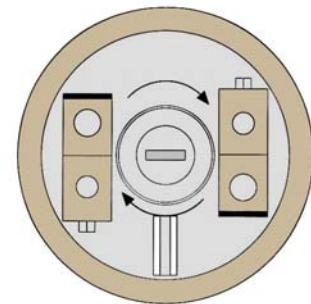

Important Test

- While pump is operating in low speed with heat, unplug the pump cord to simulate a pump failure.
- The heater should turn off and 3 Flashing Dots should appear below the temperature display.
- **If the heater remains on, quickly plug the pump back in and repeat the above steps.**

If there is a problem with the temperature sensor, 33°F will be displayed on the spaside control though the water temperature may be higher. After 1-hour, 3 Flashing Dots will appear under this reading signifying that the system has not seen a rise or fall in the reading indicating a faulty temperature sensor. The system is constantly verifying that the reading of the temperature probe is within limits.

Note that the temperature of the water should be over 35°F to perform the following steps. Press a key after each step to reset the system. Power can remain On.

- Verify that the temperature sensor is properly connected to the printed circuit board.
- Disconnect the sensor connector and try and clean the connector pins. A small coating of film can cause a bad connection. Also inspect for bent pins.
- Reconnect the sensor.
- If the error indication does not go away, replace the sensor with a spare and place the probe in the spa water.
- If this solved the problem, replace the sensor.
- Replace the printed circuit board if the problem has not been corrected.



HT-2 / 9600 Error Messages

Over Temperature

If **3 Flashing Dots** appear below the displayed temperature and at the same time the LED error indicator on the printed circuit board is illuminated, a problem with the High-Limit sensor has been detected or an over temperature condition has occurred. This will appear whenever the water temperature read by the High-Limit sensor exceeds 115°F.

Power to the system must be turned off then on again to reset the system.
Power can remain On.

- Open the access panel on the control box to verify that the Hi-Limit temperature sensor is properly connected (the cable is connected at the printed circuit board, the probe is clamped to the heater housing with a retaining plate).
- Disconnect the sensor connector from the printed circuit board and try to clean the connector pins. A small coating of film can cause a bad connection. Also inspect for bent pins.
- Reconnect the sensor. If the **HL** message is still displayed on the Spaside control, replace the sensor with a spare. If this solved the problem, replace the sensor
- Replace printed circuit board if the problem has not been corrected.
- With an accurate thermometer measure the temperature of the water.
- Check to see if the heater housing is hot.
- If the heater housing is hot, check for an obstructive flow of water (closed valves or dirty filter).
- After clearing any obstructions, cycle the power to the system off then on. If the error is still occurring, replace system circuit board.

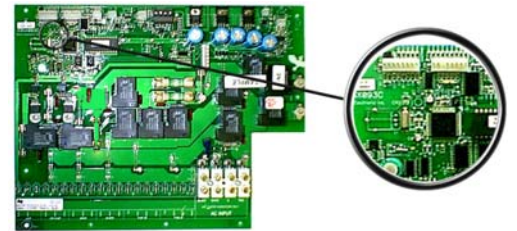

If the reading is below 115°F:



HT-2 / 9600 Error Messages

Over Temperature

If the temperature of the water is at or higher than 115°F and the display on the Spaside control is the right temperature, perform the following tests.

If the weather is very warm:

- Remove the spa cover. Wait until the spa water cools down (Turn on the Air Blower and add cold-water if necessary).

If the weather is not a factor:

- Lower the Set Temperature below the actual temperature of the water (The Heater Icon on the Spaside control should turn Off).
- Open the access panel on the control box. With a voltmeter, read the voltage between the two heater terminals on the printed circuit board. **If you do not read 240 VAC**, the pump may be overheating the water during the filtration cycle. Lower the filter cycle duration.
- **If you do read 240 VAC**, replace the printed circuit board.

To Lower the Filter Cycle Duration

- Press the Program Key: **CL** will appear.
- Press the Blower key until **Fldu** is displayed.
- Press the Light Key to enter and change the parameter.
- Use the Down Arrow key to lower the duration (Off to 12:00 for constant filtration).
- Press the Light Key to save the change.

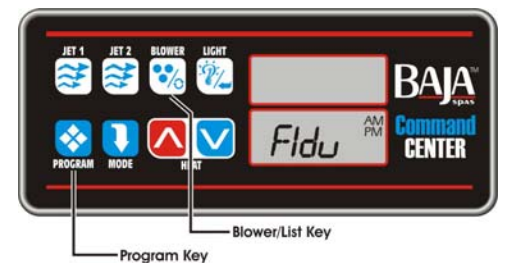
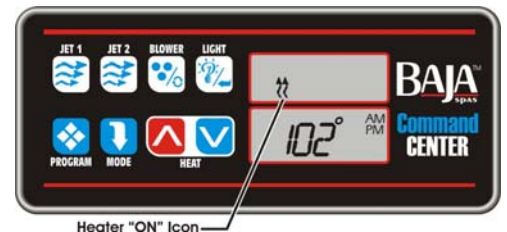

HT-2 / 9600 Error Messages

Over Temperature

If the temperature of the water is at or higher than 115°F and the display on the Spaside control does not show the right temperature, perform the following tests.

- Verify that the temperature sensor is inserted properly and that cold air cannot affect its readings.
- Use foam to insulate the sensor from cold air if this is the source of the problem.
- Verify that the temperature sensor is properly connected to the system circuit board.
- Replace the printed circuit board if the message still appears on the display.

HT-2 / 9600 Error Messages

Freeze Protection

The systems freeze protection begins in the "Smart Winter Mode". If the air temperature goes below 59°F, the system will activate any pump that has not been started in the last 2 hours for a period of 1 minute. The system will stay in this mode for a period of 24-hours. The frequency of the 1-minute cycles will increase as the air temperature drops. The Filter Cycle Icon will flash while in this mode. If the complaint is that the customer's pumps are coming on by themselves, this may be the cause. If the spa water temperature falls below 49°F the low speed pump and heater will be turned on until the water temperature reaches 60°F. During this mode all other functions of the spaside control will be disabled and the Filter Icon will be flashing in the upper display window.

Power can remain On.

- Verify the temperature of the water with an accurate thermometer
- If the water temperature is **lower** than the desired temperature, measure the voltage at the heater terminals on the printed circuit board.
- **If you read around 240vac**, the freeze protection is working properly.
- **If you do not read 240vac**, refer to the "Spa Is Not Heating" section of this manual.



It is possible to customize the program parameters of the system by modifying them directly from the spaside control.

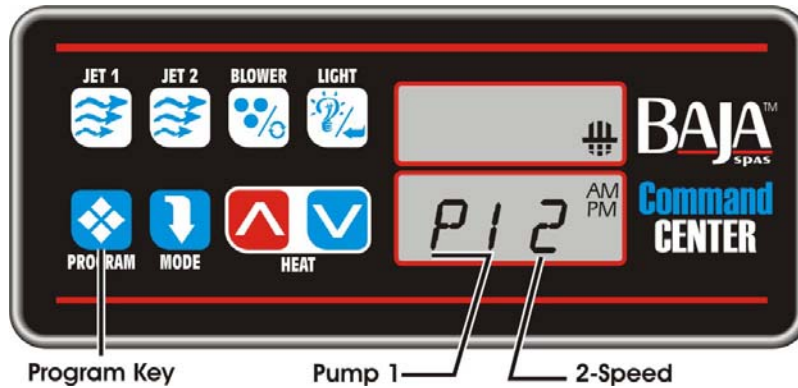

To enter the Low Level Programming press and hold the Program Key for 20 seconds until the first programming parameter appears, which is **P1** for Pump 1. Use the Up and Down Arrow Keys to increase or decrease the programming value. Press the Light Key to continue through each programming parameter using the Up and Down Arrow Keys to modify the value. You must continue through all parameters to exit this mode.

- P1 (Pump 1)** **Value 1** – Single Speed **Value 2** – Dual Speed

- P2 (Pump 1)** **Value 0** – No Second Pump **Value 1** – Single Speed **Value 2** – Dual Speed

- bL (Blower)** **Value 0** – No Air Blower **Value 1** – Single Speed / 20 minute timeout
Value 2 – Two Speed / 20 min. timeout **Value 3** – Three Speed / 20 min. timeout
Value 4 – Single Speed / 2-hour timeout **Value 5** – Single Speed / 6-hour timeout
Value 6 – Single Speed / 12-hour timeout

- L1 (Light)** **Value 0** – No Light **Value 1** – 12VAC Single Intensity
Value 2 – 12VAC Three Intensities **Value 3** – 120VAC Light

- O3 (Ozone)** **Value 0** – No Ozone **Value 1** – On during filtration only **Value 2** – Always On

- AU (Fiber Optic)** **Value 0** – No Fiber Optics **Value 1** – Fiber Optics Installed

- Ti (Time)** **Value 12** – Standard Clock **Value 24** – 24-hour (military clock)

- CU (Current)** **Value 0** – No Heat with High Speed Pump or Blower (120VAC)
Value 1 – No Current Restriction (240VAC)

- Cp (Circ. Pump)** **Value 0** – No Circulation Pump **Value 1** – Regulated with Spa Temperature
Value 2 – Always On

- r (Sensor Calibration)** Value can be adjusted from 46.0 to 55.9 (this number is marked on the temperature sensor and is programmed at the factory).

HT-2 / 9600 Identified Problems

Nothing Works!

If everything is connected properly and nothing seems to work, there is probably a problem with the power supply. **If you detect Low or High voltage conditions at the input power connection contact an electrician.** Perform the following tests to identify and correct the problem:

240V Operation

- Measure the input voltage between Line 1 and Line 2 at the printed circuit board terminal block. You should read approximately **240VAC**.
- Measure the voltage between Line 1 and Neutral. You should read approximately **120VAC**.
- Measure the voltage between Line 2 and Neutral. You should read approximately **120VAC**.

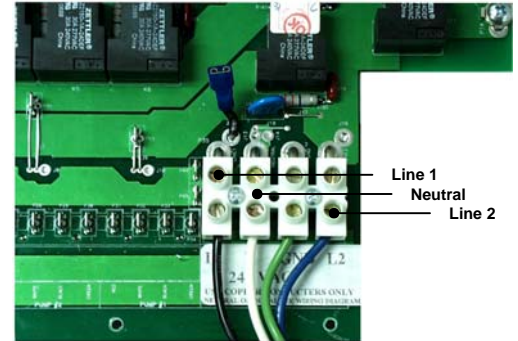

Spaside Control

- If you are getting good voltage readings but nothing seems to work, verify that the Spaside control is properly connected to the printed circuit board.

Transformer

- If there is still no operation, disconnect the transformer from the printed circuit board and clean the connector pins. A small coating of film may cause a bad connection. Reconnect the plug.
- If there is still no operation, replace the transformer fuse.
- Replace the Transformer if the problem persists.
- If still nothing works, replace the printed circuit board.

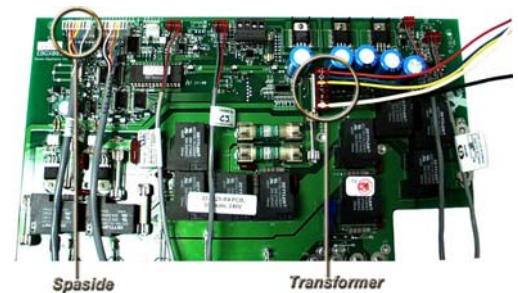

If the spa seems to not be heating the water, perform the following tests to correct the problem:

- Check the Spaside control for an error message. If this is the case, go to the specific section that refers to that message.
- Verify that there is a call for heat when the Set Point is increased. Press the Up Arrow Key to increase the temperature set point.
- Verify that the Heater Icon on the Spaside control appears. The icon will be solid when the heater is working. It will flash if there is a call for heat but the heater has not yet started.



If the Heater Icon does not appear:

- With an accurate thermometer, measure the temperature and compare your reading with the temperature value displayed on the Spaside control.
- If the values are different (± 2 °F), check to make sure the sensor is properly inserted into the dry-well or if hot air is affecting its readings. If so, insulate the back of the sensor.
- If the problem still exists, replace the temperature sensor with a spare one. If the spa is still not heating, replace the printed circuit board.

HT-2 / 9600 Identified Problems

If the Heater Icon does appear:

- Open the access panel on the control box and measure the voltage between the two heater terminals at the printed circuit board. Replace the board if you are not getting a reading of **240VAC**.
- If voltage reading is good, verify that the nuts securing the heater wiring to the heater element are secure (on models utilizing the Versi-Heat remote heater, insure that the connection at the control box 9-pin connection is secure also). If not, tighten the nuts to the element. If the problem has not been solved, replace the heater element.

Spa Is Not Heating!



HT-2 / 9600 Identified Problems

Pump 1 Does Not Work!

If Pump 1 does not operate, perform the following tests to correct the problem:

To increase the life of the relay, we are using a circuit called snubber on the pump relay. With this type of circuit, if no pump is connected to an output and the relays are open, the voltmeter will still read voltage of around 60 volts. This is normal.

It is important to measure voltage when the pump is connected to the pack. Power must remain On.

Pump 1 Icon does not appear

- Check to see if there is an error message on the Spaside control. If this is the case, go to the specific section that refers to that message.
- Check Spaside control to see if the Pump 1 Icon appears when the Pump 1 key is depressed.
- Use your spare Spaside control to verify if the keypad is defective. If changing the Spaside control fixed the problem, replace the Spaside control.
- If the Pump 1 Icon still does not appear, replace the printed circuit board.



HT-2 / 9600 Identified Problems

Pump 1 Icon does appear

- Verify that Pump 1 works in one of the speeds.
- Verify that the Low Level Programming for **P1** is correct (refer to the Programming section of this manual).

Pump 1 Does Not Work!

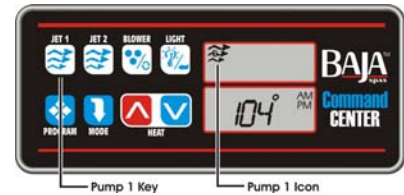

If Pump 1 does not work in any speed, perform the following tests to correct the problem:

- If Pump 1 does not work in either speed, replace the Pump 1 fuse.
- If replacing the fuse is not effective or if Pump 1 works in one of two speeds, read the voltage at the printed circuit board for both speeds.
- Turn Pump 1 to High speed and measure the voltage between the white wire and the red wire.
- Turn Pump 1 to Low speed and measure the voltage between the white wire and the black wire. If the voltage readings are good, replace Pump 1. If they are not, replace the printed circuit board.

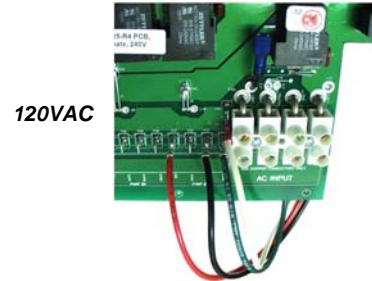

HT-2 / 9600 Identified Problems

Pump 2 Does Not Work!

If Pump 2 does not operate, perform the following tests to correct the problem:

To increase the life of the relay, we are using a circuit called snubber on the pump relay. With this type of circuit, if no pump is connected to an output and the relays are open, the voltmeter will still read voltage of around 60 volts. This is normal.

It is important to measure voltage when the pump is connected to the pack. Power must remain On.

- Check to see if there is an error message on the Spaside control. If this is the case, go to the specific section that refers to that message.
- Check Spaside control to see if the Pump 2 Icon appears when the Pump 2 key is depressed.

HT-2 / 9600 Identified Problems

Pump 2 Does Not Work!

Pump 2 Icon does not appear

- Use your spare Spaside control to verify if the keypad is defective. If changing the Spaside control fixed the problem, replace the Spaside control.
- If the Pump 2 Icon still does not appear, replace the printed circuit board.



Pump 2 Icon does appear

- Verify that Pump 2 works in one of the speeds.
- Verify that the Low Level Programming for P2 is correct (refer to the Programming section of this manual).

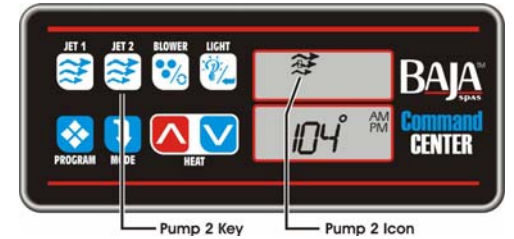

If Pump 2 does not work in any speed, perform the following tests to correct the problem:

- If Pump 2 does not work in either speed, replace Pump 2 fuse.
- If replacing the fuse is not effective or if Pump 2 works in one of two speeds, read the voltage at the printed circuit board for both speeds.
- Turn Pump 2 to High speed and measure the voltage between the white wire and the red wire connectors.
- Turn Pump 2 to Low speed and measure the voltage between the white wire and the black wire. If the voltage readings are good, replace Pump 2. If they are not, replace the printed circuit board.

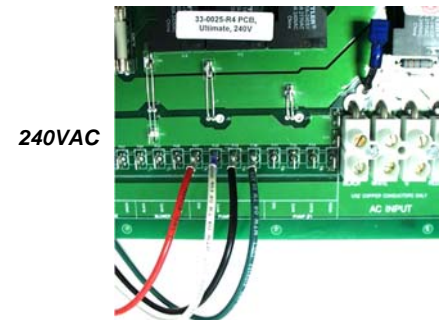
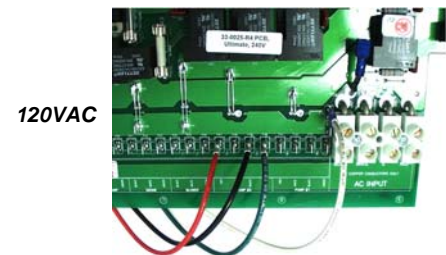

HT-2 / 9600 Identified Problems

Blower Does Not Work!

If the Blower does not work, perform the following tests to correct the problem:

To increase the life of the triac, we are using a circuit called snubber on the blower relay. With this type of circuit, if no blower is connected to an output and the triac is open, the voltmeter will still read voltage of around 60 volts. This is normal.

It is important to measure voltage when the pump is connected to the pack.
Power must remain On.

- Check to see if there is an error message on the Spaside control. If there is, go to the specific section that refers to that message.
- If the Blower Icon does not appear on the Spaside control, replace Spaside control.
- If the Blower still does not work, replace printed circuit board.

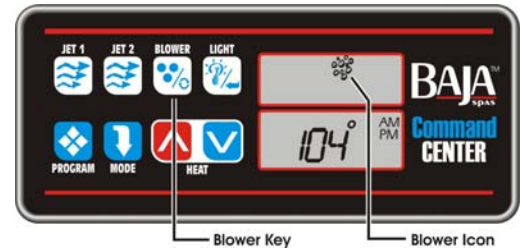

If the Blower Icon does appear on the Spaside control but the blower still does not operate, perform the following tests to correct the problem:

- If the Blower Icon appears on the Spaside control with the Blower in High speed, measure the voltage between the white wire and black wire connectors.
- If you are not getting a good voltage reading, replace the Blower fuse. If you are still not getting a good voltage reading, replace the printed circuit board.
- If the voltage measurements are good, try to restart the blower after it has had time to cool down.
- If the Blower **does** restart, it is not getting sufficient air to cool it down. Create a larger opening.
- If the Blower **does not** restart, replace the Blower.

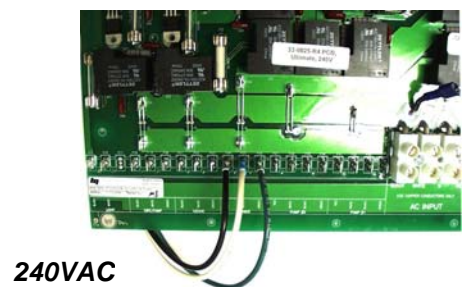
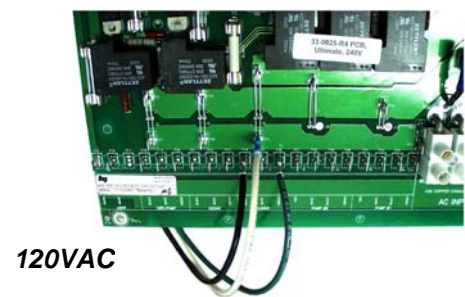

HT-2 / 9600 Identified Problems

Ozonator Does Not Work!

If so equipped and the Ozonator does not work, perform the following tests to correct the problem:

To increase the life of the relay, we are using a circuit called snubber on the ozonator relay. With this type of circuit, if no ozonator is connected to an output and the relays are open, the voltmeter will still read voltage of around 60 volts. This is normal.

It is important to measure voltage when the ozonator is connected to the pack. Power must remain On.

Please take note that the ozonator output will be shut off when Pump 1, Pump 2 or the Blower has been turned on manually.

- Check to see if the Filter Cycle Icon appears on the Spaside control.
- If not start a filtration cycle.
- Press the Program Key.
- Press the Blower Key until **Flon** is displayed.
- Press the Light Key to enter the parameter. Use the Up & Down Arrow Keys to adjust the time so the cycle will start immediately.
- Press the Program Key to save the change.
- Once the filtration cycle has been started, measure the voltage at the Ozonator white wire end and black wire connectors.
- Replace the Ozonator if you have a good voltage measurement.
- Replace the Ozonator fuse if you are not getting a good voltage measurement.
- If you are still not getting a good voltage reading, replace the printed circuit board.

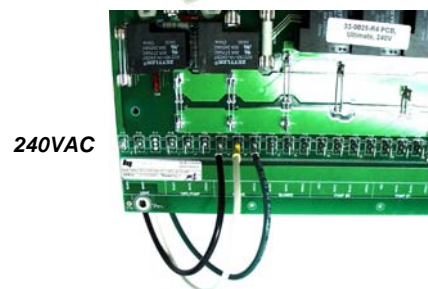
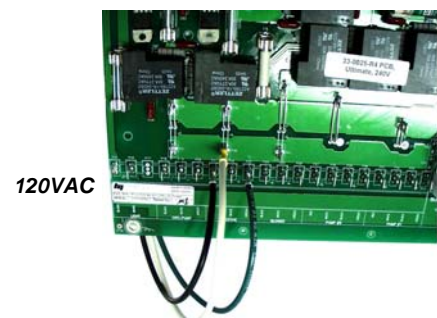
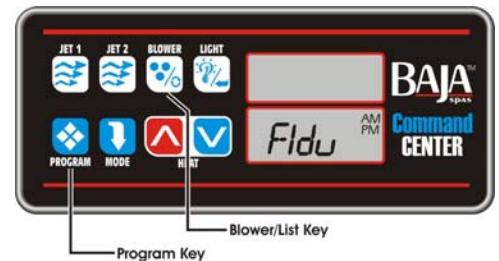

HT-2 / 9600 Identified Problems

Spa Light Does Not Work!

If the spa light does not work, perform the following tests to correct the problem:

**It is important to measure voltage when the light is connected to the pack.
Power must remain On.**

- The first step is to replace the bulb of the spa light.
- If the light is still not coming on, verify that the Light Icon on the Spaside control appears when the light key is pressed.
- If the Light Icon **does not** appear, use your spare Spaside control to verify if the keypad is defective. If it is, replace the Spaside control. If not, replace System Board.
- If the Light Icon **does** appear but the light does not come on, make sure the light is set for its highest intensity (Icon is solid not flashing). Open the access panel and measure the voltage between the two wires of the light connector (P15 & P16) on the printed circuit board. If you have **12 VAC**, replace the light socket.
- If you do not read any voltage, replace the light fuse on the board.
- If the problem persists, replace the printed circuit board.

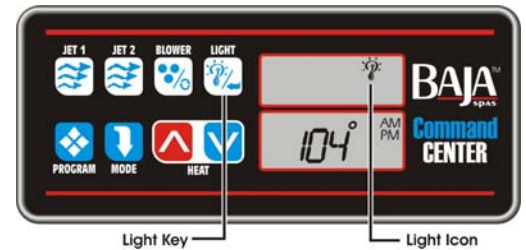

HT-2 / 9600 Identified Problems

Fiber Optic Does Not Work!

If the fiber optic does not work, perform the following tests to correct the problem:

- The Fiber Optic (green) receptacle is “hot”. With input power on, read the voltage across P44 and Line 1.
- Verify that the interface module is properly connected to the printed circuit board.
- Disconnect the connector and try and clean the connector pins. A small coating of film can cause a bad connection. Also inspect for bent pins.
- Verify that the Low Level Programming for AUX is correct (AUX 1), refer to the Programming section of this manual.
- With the interface box connected to the fiber optic module, take a voltage reading across the white and red wires and the white and black wires at the fiber optic. With the system set to control the light and the color wheel, you should read 120 VAC.
- If you have a good voltage reading, replace the fiber optic.
- If you do not get a good reading, replace the interface module.
- If the fiber optic still does not work, replace the printed circuit board.

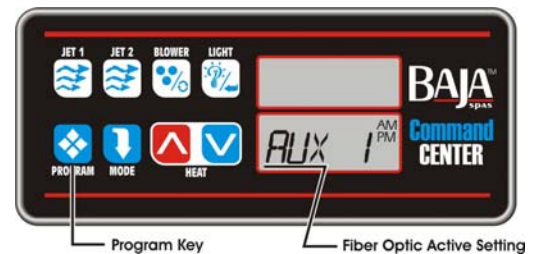
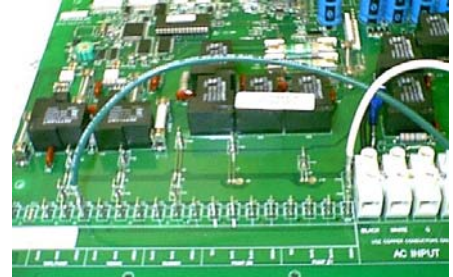

HT-2 / 9600 Identified Problems

Spaside Does Not Work!

If the keys on the Spaside control seem to not be working, perform the following tests to correct the problem:

- Replace the Spaside control with a spare one.
- Check to see if the keys are responding.
- If they are, replace the Spaside control.
- Check the external spaside control receptacle connection (if applicable).
- If the spaside is still not responding, replace printed circuit board.

