

Contents

Updated 1/05

Contents	1
Safety Warnings	2
<i>Before Using the Spa</i>	2
<i>Safety Precautions</i>	4
<i>Safety Signs</i>	4
<i>Canadian Installations</i>	5
<i>Hyperthermia Warning</i>	6
Welcome	7
Spa Specifications	8
Components	10
<i>Equipment Area and Interior Components</i>	10
<i>Exterior Components</i>	12
<i>Filter Assembly</i>	15
Installation Procedures and Guidelines	16
Electrical Wiring	17
<i>Square D Diagram</i>	19
<i>Siemens Diagram</i>	20
Filling the Spa	21
Operating Instructions	22
<i>Using the Pumps</i>	22
<i>Using the Light</i>	23
<i>Adjusting the Water Temperature</i>	23
<i>Programming Filter Cycles</i>	24
<i>Water Heater Auto Start</i>	25
<i>Economy Mode</i>	25
Balancing Your Spa's Water	26
<i>Ozone Purification System</i>	26
<i>General Water Chemistry</i>	26
<i>Sanitizers</i>	26
<i>pH Balance</i>	27
<i>Total Alkalinity</i>	27
<i>Final Thoughts on Water Chemistry</i>	27
General Maintenance	28
<i>Maintenance Cycles</i>	28
<i>GFCI Maintenance</i>	28
<i>Heating Time</i>	28
<i>Cleaning the Filter</i>	28
<i>Changing the Water</i>	29
<i>Draining the Spa</i>	29
<i>Cabinetry Maintenance</i>	29
<i>Checking for Leaks</i>	30
<i>Overall Maintenance Checklist</i>	30
Troubleshooting	31
<i>3 Flashing Dots</i>	31
<i>Flashing Water Temperature</i>	31
<i>Flashing Filter Cycle Indicator</i>	32
<i>Replacing the Light Bulb</i>	32
<i>Spa is Not Heating</i>	33
<i>Pump 1 Not Working</i>	33
<i>Pump 2 or 3 Not Working</i>	33
<i>Low Water Pressure/Jets Not Working</i>	34
<i>Circuit Breaker Tripping</i>	34
<i>Checking the Fuses</i>	34
<i>Pumps Making Noise</i>	35
<i>No Display on the Topside Control</i>	35
<i>Ozonator Not Working</i>	35

Safety Warnings

IMPORTANT SAFETY INSTRUCTIONS. READ AND FOLLOW ALL INSTRUCTIONS. SAVE THESE INSTRUCTIONS!

Read the entire owner's manual & safety instructions before operating the spa. When installing the spa, basic safety precautions should always be followed, including the following:

WARNING: If the Keypad is physically damaged, it should be replaced immediately. Do not use the spa if the keypad has been damaged!

WARNING: To reduce the risk of injury, do not permit children to use this product unless they are closely supervised at all times by adults.

WARNING: A grounding wire connector is provided on this unit to connect a minimum No. 8 AWG (8.4 mm²) solid copper conductor between this unit and any metal equipment, metal enclosures of electrical equipment, metal water pipe or conduit within 5 feet (1.5 m) of the unit.

DANGER: RISK OF ACCIDENTAL DROWNING: Extreme caution must be exercised to prevent unauthorized access by children. To avoid accidents, ensure that children cannot use this spa unless they are closely supervised at all times by adults.

DANGER: RISK OF INJURY: The suction fittings in this spa are sized to match the specific water flow created by the pump. Should the need arise to replace the suction fittings or the pump, be sure to replace with same model suction fittings for safety and compatible flow rates.

Never operate the spa if the suction fittings are broken or missing. Never replace a suction fitting with one rated less than the flow rate marked on the original suction fittings.

DANGER: RISK OF INJURY: Do not remove suction grate. Suction through drains and skimmers are powerful when the jets in the spa are in use. Damaged suction grate can be hazardous to children and adults with long hair. Should any part of the body or hair be drawn into these fittings or stuck onto the fittings turn off the spa immediately. As a precaution, long hair should NOT be allowed to float freely in the spa.

DANGER: RISK OF ELECTRIC SHOCK: Install at least 5 feet (1.5m) from all metal surfaces. As an alternative a spa may be installed within 5 feet (1.5m) of metal surfaces if, in accordance with the National Electrical Code, each metal surface is permanently connected by a minimum No. 8 AWG (8.4 mm²) solid copper conductor to the wire connector on the terminal box that is provided for this purpose.

DANGER: RISK OF ELECTRIC SHOCK: Do not permit any electric appliance, such as a light, hair dryer telephone, radio, or television, within 5 feet (1.5 m) of the spa. Never operate any electrical appliances from inside the spa or while wet.

DANGER: The electrical supply for this spa must include a suitable rated switch or circuit breaker to open all ungrounded supply conductors. The disconnect must be readily accessible and visible to the spa occupant but installed at least 5 feet (1.5m) from the spa water.

WARNING: *To reduce the risk of injury:* The water in a spa should never exceed 104°F (40°C). Water temperatures between 100°F (38°C) and 104°F (40°C) are considered safe for a healthy adult. Lower water temperatures are recommended for young children and when spa use exceeds 10 minutes.

WARNING: *To reduce the risk of injury:* Since excessive water temperatures have a high potential for causing fetal damage during the early months of pregnancy, pregnant women should limit spa water temperatures to 100°F (38°C).

WARNING: *To reduce the risk of injury:* Before entering a spa, the user should check the water temperature with an accurate thermometer since the tolerance of water temperature-regulating devices can vary and not reflect the proper temperature.

Safety Warnings

WARNING: *To reduce the risk of injury:* The use of alcohol, drugs, or medication before or during spa use may lead to unconsciousness with the possibility of drowning.

WARNING: *To reduce the risk of injury:* Obese persons and persons with a history of heart disease, low or high blood pressure, circulatory system problems, or diabetes should consult a physician before using a spa.

WARNING: *To reduce the risk of injury:* Persons using medication should consult a physician before using a spa since some medication may induce drowsiness while other medications may affect heart rate, blood pressure, and circulation.

WARNING: *To reduce the risk of injury:* Do not use spa immediately after strenuous exercise.

CAUTION: Persons suffering from heart disease, diabetes, high or low blood pressure, any condition requiring medical treatment, pregnant women, the elderly, or infants should consult with a physician before using a spa.

CAUTION: The Consumer Product Safety Commission has stated that the water temperature in a spa or hot tub should not exceed 104°F. Immersion in water in excess of 104°F can be hazardous to your health.

CAUTION: Observe a reasonable time limit when using the spa. Long exposures at higher temperatures can cause high body temperature. Symptoms may include dizziness, nausea, fainting, drowsiness, and reduced awareness. These effects could result in possible drowning.

CAUTION: Do not use the spa under the influence of alcohol, narcotics, or other drugs. Use of the spa under these conditions may lead to serious consequences.

CAUTION: Always test the spa water temperature before entering the spa. Enter and exit the spa slowly. Wet surfaces can be very slippery.

CAUTION: Never bring any electrical appliance into or near the spa. Never operate any electrical appliance from inside the spa or when you are wet.

CAUTION: Proper chemical maintenance of spa water is necessary to maintain safe water and prevent possible damage to spa components.

CAUTION: Use the spa straps and locking clips to secure the cover when not in use. This will help to discourage unsupervised children from entering the spa and keep the spa cover secure in high wind conditions. There is no representation that the cover, clip tie downs, or actual locks will prevent access to the spa.

Safety Warnings

SPA SAFETY PRECAUTIONS:

- ❑ Always enter and exit a spa slowly.
- ❑ Do not use the spa alone.
- ❑ Use a licensed electrician to make all electrical connections.
- ❑ Maintain water chemistry as described in this handbook.
- ❑ Persons with longer hair should use a bathing cap.
- ❑ Refer to information on hyperthermia on page 35.
- ❑ DO NOT allow anyone to stand on the spa cover. It is not designed to support weight.
- ❑ Before entering the spa, always measure the water temperature with an accurate thermometer. Tolerance of water temperature regulating devices can vary as much as ± 5 F (3° C). Always check the spa water temperature before entering.
- ❑ Since excessive water temperature has a high potential for causing fetal damage during early months of pregnancy, pregnant or possibly pregnant women should limit spa water temperatures to 100°F (38°C). Always consult your doctor prior to using a spa.
- ❑ Children's body temperature can increase more rapidly than adults in the same water with elevated temperatures (above 98°F). Children should spend less time in water above body temperature than adults.
- ❑ The use of alcohol, drugs, and/or medication before or during spa use may lead to unconsciousness, hypothermia, serious injury or the possibility of drowning.
- ❑ Persons suffering from obesity or with a medical history of heart disease, diabetes, high or low blood pressure, or circulatory system problems should consult with their physician before using the spa.
- ❑ Persons on medication should consult with their physician before entering the spa since some medication may induce drowsiness while other medication may affect heart rate, blood pressure, and circulation.
- ❑ People with infections, sores, or skin abrasions should not use the spa. Warm and hot water temperatures may allow the growth of infectious bacteria if not properly disinfected.
- ❑ Test the GFCI (Ground Fault Circuit Interrupter) unit before each use. (Refer to instructions provided by GFCI manufacturer.)
- ❑ Do not service or repair any equipment without making sure the circuit breaker and/or all power to the spa is off.
- ❑ Cover must be kept on the spa at all times when not in use and locked, especially if children are present.

SAFETY SIGNS

Each spa has been provided with a warning sign that outlines safety precautions. This sign should be permanently placed in a location that is visible to all spa users. This sign has been mounted permanently to the front of the spa. Replacement signs can be obtained from:

Hawkeye Manufacturing, Inc
1125 Commerce Rd
Richmond, VA 23220

Safety Warnings

CANADIAN INSTALLATIONS IMPORTANT SAFETY INSTRUCTIONS (CSA SAFETY INFORMATION)

When using this electrical equipment, basic safety precautions should always be followed, including the following:

1. READ AND FOLLOW ALL INSTRUCTIONS

2. A colored terminal or a terminal marked G, GR, Ground, Grounding, or the symbol _____ is located inside the supply terminal box or compartment. To reduce the risk of electric shock, this terminal must be connected to the grounding means provided in the electric supply service panel with a continuous copper wire equivalent in size to the circuit conductors supplying this equipment. *IEC Publication 417, Symbol 5019

3. At least two lugs marked "BONDING LUGS" are provided on the external surface or on the inside of the supply terminal box/compartment. To reduce the risk of electric shock, connect the local common bonding grid in the area of the hot tub or spa to these terminals with an insulated or bare copper conductor not smaller than No. 6 AWG.

4. All field-installed metal components such as rails, ladders, drains or other similar hardware within 3 meters of the spa or hot tub shall be bonded to the equipment grounding bus with copper conductors not smaller than No. 6 AWG.

5. SAVE THESE INSTRUCTIONS.

WARNING: Children should not use spas or hot tubs without adult supervision.

AVERTISSEMENT: NE PAS LAISSER LES ENFANTS UTILISER UNE CUVE DE RELAXATION SANS SURVEILLANCE.

WARNING: Do not use spas or hot tubs unless all suction guards are installed to prevent body and hair entrapment.

AVERTISSEMENT: POUR ÉVITER QUE LES CHEVEUX OU UNE PARTIE DU CORPS PUISSENT ÊTRE ASPIRÉS, NE PAS UTILISER UNE CUVE DE RELAXATION SI LES GRILLES DE PRISE D'ASPIRATION NE SONT PAS TOUTES EN PLACE.

WARNING: People using medications and/or having adverse medical history should consult a physician before using a spa or hot tub.

AVERTISSEMENT: LES PERSONNES QUI PRENNENT DES MÉDICAMENTS OU ONT DES PROBLÈMES DE SANTÉ DEVRAIENT CONSULTER UN MÉDECIN AVANT D'UTILISER UNE CUVE DE RELAXATION.

WARNING: People with infectious diseases should not use a spa or hot tub.

AVERTISSEMENT: LES PERSONNES ATTEINTES DE MALADIES INFECTIEUSE NE DEVRAIENT PAS UTILISER UNE CUVE DE RELAXATION.

WARNING: To avoid injury, exercise care when entering and exiting the spa or hot tub.

AVERTISSEMENT: POUR ÉVITER DES BLESSURES, USER DE PRUDENCE EN ENTRANT DANS UNE CUVE DE RELAXATION ET EN SORTANT.

WARNING: Do not use drugs or alcohol before or during the use of a spa or hot tub to avoid unconsciousness and possible drowning.

AVERTISSEMENT: POUR ÉVITER L'ÉVANOUISSEMENT ET LA NOYADE ÉVENTUELLE, NE PRENDRE NI DROGUE NI ALCOOL AVANT D'UTILISER UNE CUVE DE RELAXATION NI QUAND ON S'Y TROUVE.

Safety Warnings

WARNING: Pregnant or possibly pregnant women should consult a physician before using a spa or hot tub.

AVERTISSEMENT: LES FEMMES ENCEINTE, QUE LEUR GROSSESSE SOIT CONFIRÉE OU NON, DEVRAIENT CONSULTER UN MÉDECIN AVANT D'UTILISER UNE CUVE DE RELAXATION.

WARNING: Water temperature in excess of 38°C may be injurious to your health.

AVERTISSEMENT: IL PEUT ÊTRE DANGEREUX POUR LA SANTÉ DE SE PLONGER DANS DE L'EAU A PLUS DE 38°C.

WARNING: Before entering the spa or hot tub, measure the water temperature with an accurate thermometer.

AVERTISSEMENT: AVANT D'UTILISER UNE CUVE DE RELAXATION MESURER LA TEMPÉRATURE DE L'EAU A L'AIDE D'UN THERMOMÈTRE PRÉCIS.

WARNING: Do not use a spa or hot tub immediately following strenuous exercise.

AVERTISSEMENT: NE PAS UTILISER UNE CUVE DE RELAXATION IMMÉDIATEMENT APRÈS UN EXERCICE FATIGANT.

WARNING: Prolonged immersion in a spa or hot tub may be injurious to your health.

AVERTISSEMENT; L'UTILISATION PROLONGÉE D'UNE CUVE DE RELAXATION PEUT ÊTRE DANGÉREUSE POUR LA SANTÉ.

WARNING: Do not permit electric appliances (such as a light, telephone, radio, television, etc.) within 1.5m of this spa or hot tub.

AVERTISSEMENT: NE PAS PLACER D'APPAREIL ÉLECTRIQUE (LUMINAIRE, TÉLÉPHONE, RADIO, TÉLÉVISEUR, ETC.) A MOINS DE 1.5 M DE CETTE CUVE DE RELAXATION.

CAUTION: Maintain water chemistry in accordance with manufacturer's instructions.

ATTENTION: LA TENUEUR DE L'EAU EN MATIÈRES DISSOUTES DOIT ÊTRE CONFORME AUX DIRECTIVES DU FABRICANT.

SAVE THESE INSTRUCTIONS

HYPERTHERMIA

Prolonged immersion in hot water may induce hyperthermia. A description of the cause, symptoms, and effects of hyperthermia are as follows: Hyperthermia occurs when the internal temperature of the body reaches a level several degrees above the normal body temperature of 98.6°F (37°C). The symptoms of hyperthermia include drowsiness, lethargy, and an increase in the internal temperature of the body. The effects of hyperthermia include:

- 1) Unawareness of impending hazard
- 2) Failure to perceive heat
- 3) Failure to recognize the need to exit spa
- 4) Physical inability to exit spa
- 5) Fetal damage in pregnant women
- 6) Unconsciousness and danger of drowning

WARNING: The use of alcohol or drugs can greatly increase the risk of fatal hyperthermia in hot tubs and spas.

AVERTISSEMENT: LA CONSOMMATION D'ALCOOL OU DE DROGUE AUGMENTE CONSIDÉRABLEMENT LES RISQUES D'HYPERTHERMIE MORTELLE DANS UNE CUVE DE RELAXATION.

Welcome!

Congratulations on the purchase of your new Hawkeye Spa!

You've just made a wonderful investment toward your own general health and well being. We are certain that you will enjoy this spa for many years to come.

By now, I'm sure you are quite anxious to get your spa up and running. Sure enough, you are closer than ever to experiencing the marvels of hydrotherapy. But before we move on to the installation, there are a few things you should know about your spa.

First, you should appreciate the intricate nature of the spa's subsystems. Having respect for the spa as a complex machine will make your ownership of it that much more rewarding. For example, it will be important that you address periodic maintenance needs, such as monitoring the water chemistry and cleaning the filter. Each of these maintenance suggestions will be addressed in this manual. We ask that you please read it in its entirety.

Again, thank you for choosing Hawkeye. We understand that sifting through a multitude of spa brands can be a tiresome, if not vexing processes. We are glad that you have chosen to join thousands of other satisfied Hawkeye customers. Enjoy!

Sincerely,
Hawkeye Manufacturing, Inc.



Spa Specifications

*Here you will find important details
for your particular spa.**

Aries

Dimensions: 87x87x39
Dry Weight: 700lbs
Water Capacity: 450 gallons
Jets: 47
Pumps: 3
Electrical: 240v, 30/50amp

Atlas

Dimensions: 87x87x39
Dry Weight: 700lbs
Water Capacity: 450 gallons
Jets: 47
Pumps: 3
Electrical: 240v, 30/50amp

Eclipse

Dimensions: 59x87x34
Dry Weight: 500lbs
Water Capacity: 200 gallons
Jets: 27
Pumps: 1
Electrical: 240v, 30/50amp

Galaxy

Dimensions: 87x87x39
Dry Weight: 825lbs
Water Capacity: 450 gallons
Jets: 43
Pumps: 3
Electrical: 240v, 30/50amp

Gemini

Dimensions: 55.5x84x31.5
Dry Weight: 500lbs
Water Capacity: 200 gallons
Jets: 18
Pumps: 1
Electrical: 110V 20A or 240v 30/50A

Genesis

Dimensions: 76x81x38
Dry Weight: 550lbs
Water Capacity: 400 gallons
Jets: 24
Pumps: 1
Electrical: 110V 20A or 240v 30/50A

Infinity

Dimensions: 76x81x38
Dry Weight: 550lbs
Water Capacity: 400 gallons
Jets: 34
Pumps: 2
Electrical: 240v, 30/50amp

Jupiter

Dimensions: 76x81x38
Dry Weight: 550lbs
Water Capacity: 400 gallons
Jets: 31
Pumps: 2
Electrical: 240v, 30/50amp

Mercury

Dimensions: 87x87x39
Dry Weight: 825lbs
Water Capacity: 450 gallons
Jets: 43
Pumps: 3
Electrical: 240v, 30/50amp

Millennium 1

Dimensions: 84x84x40
Dry Weight: 725lbs
Water Capacity: 450 gallons
Jets: 35
Pumps: 1
Electrical: 240v, 30/50amp

Spa Specifications

Millennium 2

Dimensions: 84x84x40
Dry Weight: 725lbs
Water Capacity: 450 gallons
Jets: 35
Pumps: 2
Electrical: 240v, 30/50amp

Neptune

Dimensions: 90x90x39
Dry Weight: 800lbs
Water Capacity: 450 gallons
Jets: 68
Pumps: 3
Electrical: 240v, 30/50amp

Odyssey

Dimensions: 78x85x39
Dry Weight: 600lbs
Water Capacity: 350 gallons
Jets: 42
Pumps: 2
Electrical: 240v, 30/50amp

Orion

Dimensions: 96x96x39
Dry Weight: 950lbs
Water Capacity: 550 gallons
Jets: 73
Pumps: 3
Electrical: 240v, 30/50amp

Sparrow

Dimensions: 46x74x29
Dry Weight: 350lbs
Water Capacity: 125 gallons
Jets: 15
Pumps: 1
Electrical: 110V 20A or 240v 30/50A

Universe

Dimensions: 76x81x38
Dry Weight: 550lbs
Water Capacity: 400 gallons
Jets: 31
Pumps: 2
Electrical: 240v, 30/50amp

Venus

Dimensions: 76x81x38
Dry Weight: 550lbs
Water Capacity: 400 gallons
Jets: 34
Pumps: 2
Electrical: 240v, 30/50amp

**Specifications are current at time of print but are subject to change*

Components

The Equipment Compartment and Interior Components

Getting to know your spa involves more than just understanding its program functions. You should be conscious of how the spa works and of the components that are working behind the scenes. To access the equipment compartment, remove the cabinet panel directly below the topside controls.

The Equipment Area

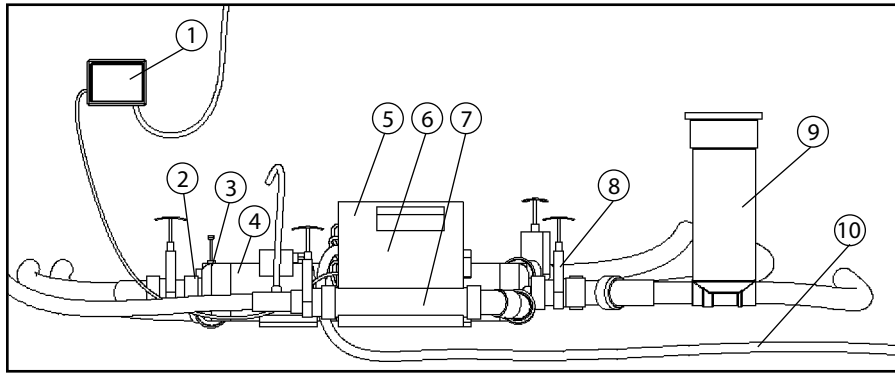

Index:

- | | | |
|--------------------|------------------|-------------------|
| 1. Ozone Generator | 5. Control Pack | 9. Filter Housing |
| 2. Pump Union | 6. Serial Number | 10. Drain Line |
| 3. Bleeder Valve | 7. Heater | |
| 4. Jet Pumps | 8. Slice Valves | |

Detailed Descriptions:

Control Pack - The control pack monitors all of the spa's functions including the heater, pumps and maintenance cycles. Inside, you will find the fuses, should you ever need to change one (refer to the Troubleshooting section). In addition, there is a wiring schematic located on the inside cover for your reference.

WARNING: DO NOT ATTEMPT TO ACCESS THE CONTROL PACK WITHOUT FIRST TURNING OFF THE ELECTRICAL SERVICE AT THE BREAKER!

Serial Number - The serial number of your spa will be written on a sticker attached to the control pack. Write this number on the back cover of your owner's manual and have it ready if you should ever call for service.

Components

Interior Components

Heater - Works with a user-defined temperature setting to heat the spa's water as it flows through the system

Ozone Generator - Releases ozone (O^3) into the spa's water to target and kill bacteria. The use of ozone is a proven method of oxidizing micro-particles in the water. The ozone generator is programmed to run independently and will not run until 45 minutes after the last function was turned off. Therefore, if you recently used the spa - or even turned on the light - the ozone generator will not come on until 45 minutes have elapsed. You will see a purple LED in the generator's display what it is operating. *(LED may be difficult to see in direct sunlight)*

Jet Pump(s) - Propels water through the spa. Our pumps have either one or two speeds. On Hawkeye Spas, the maintenance cycles use a low-speed function of pump #1 to filter and heat the water during off-peak times.

Pump Bleeder Valve - Located on the back side of the pump near the union, this valve looks like a small, plastic wingnut. Should you need to release an air pocket in the system, loosen this valve to release the air. Once water begins to spray out heavily, tighten the valve again. Make sure that you do not remove the valve completely when bleeding the pumps.

Pump Unions - The pump unions are the large, white rings that connect the pumps to the plumbing system of the spa. Make sure the pump unions are tight before filling your spa for the first time. Often, they are loosened or disconnected before shipment from the factory.

Slice Valves - The slice valves are used to cut off water flow to the pumps should you ever need to remove a pump. For normal operation, the slice valves should remain in the up, or opened position.

Filter Housing - Creates a powerful suction used to pull particles and debris through the filter element. See schematic on page 15.

Drain Line - The drain line ends at a valve located on the exterior of the spa. Use this valve when removing water from the spa.

Components

Exterior Components

Overhead View

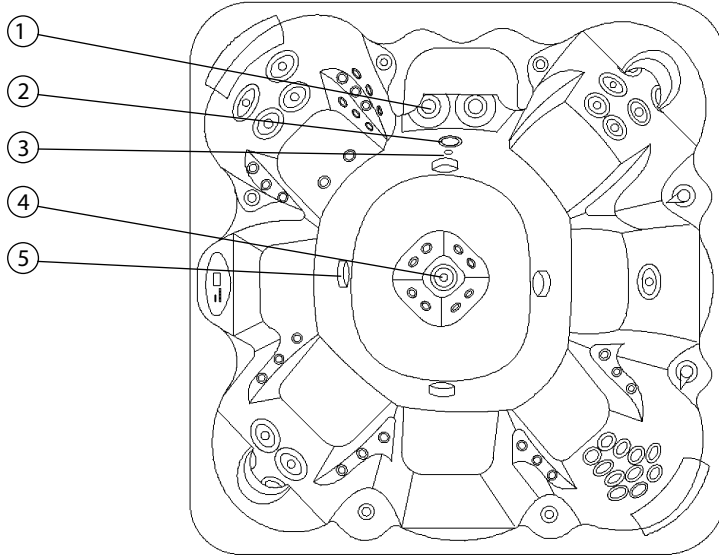

Angle View

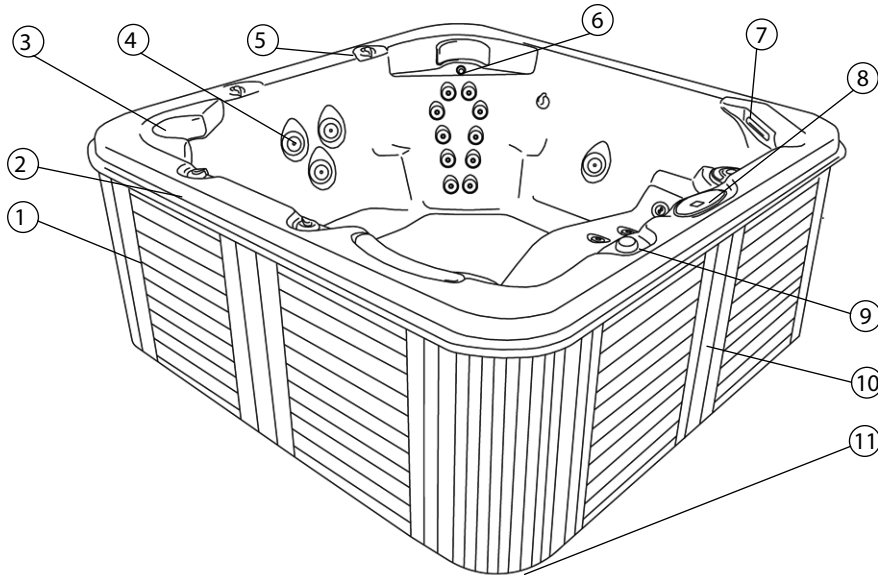

Components

Exterior Components

Overhead View Index:

- | | | |
|------------------|----------------|-------------------|
| 1. Filter Intake | 3. Ozone Jet | 5. Intake Suction |
| 2. Light | 4. Volcano Jet | |

Detailed Descriptions:

Filter Intake - Point at which water is drawn into the filter assembly to remove both large debris and small particles. Refer to the next page for a drawing of the filter assembly.

Light - Illuminates the spa water for nighttime use.

Ozone Jet - Releases ozone into the water during maintenance cycles.

Volcano Jet - A powerful, eruption-style jet that is perfect for foot massages.

Intake Suction - Point at which water is drawn into the pumps to be recirculated and propelled through the jets.

Angle View Index:

- | | |
|---------------------------|---------------------------|
| 1. Cabinet Skirt | 7. Waterfall |
| 2. Mahogany Top Rail | 8. Topside Controls |
| 3. Pillows | 9. Waterfall Controls |
| 4. Customizable Jets | 10. Equipment Compartment |
| 5. Diverter Valve | 11. Drain Valve |
| 6. Neck and Shoulder Jets | |

Detailed Descriptions:

Topside Controls - This control panel gives you unrestricted access to all of the spa's functions. Refer to the "Operating Instructions" section to learn how to operate and program the spa.

Diverter Valve - Allows you to control water pressure and direct water to other areas of the spa.

Waterfall - Provides the soothing sounds of cascading water for an auditory relaxation experience.

Components

Exterior Components

Waterfall Control - Adjusts the flow of water to the waterfall. Power to the waterfall is controlled by Pump 1.

Customizable Jets - You can remove and swap jets by turning them counter-clockwise. The jets can also be turned off by turning clockwise.

Bottom Drain Valve - Located on the kick plate of the spa, the drain valve allows you to attach a garden hose for easy drainage. To open the valve, turn counterclockwise and pull out. Conversely, push the valve in and turn clockwise to stop the flow of water.

Neck and Shoulder Jets - Using a reverse-mold technology, our neck and shoulder therapy system targets tense muscles with a downward massage.

Top Rail - On certain models, a mahogany top rail gives the spa's cabinet a hand-crafted appearance.

Cabinet Skirt - Made of either solid mahogany or a wood synthetic, the cabinet skirt is hand-made to fit each spa. For care of the cabinet, refer to the Maintenance section of this manual.

Equipment Compartment - Located directly below the topside controls, the equipment compartment can be accessed by removing the screws that hold this cabinet in place.

Pillows - Cushioned head rests allow you to sink comfortably into each seat.

Components

Filter Assembly

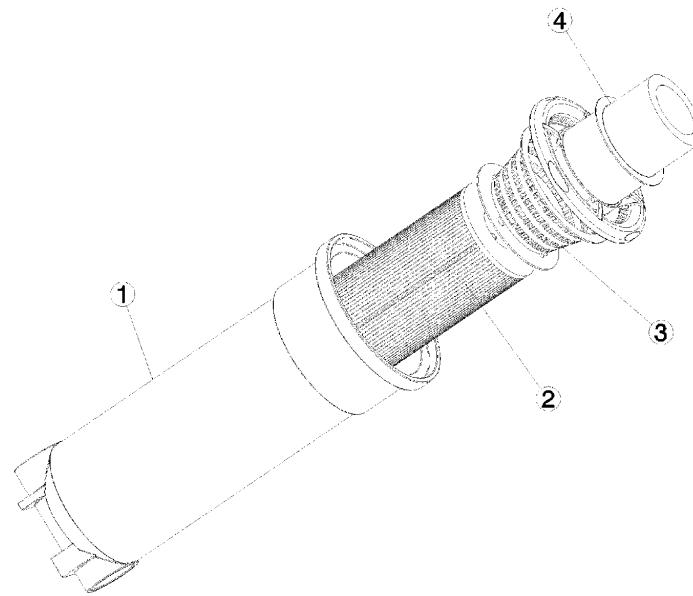

Index and Descriptions:

1. **Filter Body** - Houses the filter element.
2. **Filter Element** - Uses dense fibers to collect micro-particles as they circulate through the water.
3. **Pre-filtration Basket** - Collects larger debris such as leaves and twigs that can cause damage to your spa's internal components.
4. **Telescoping Skimmer** - Floats at the water's surface to collect floating debris.

Installation Procedures and Guidelines

Where to place your spa!

OK, so you've just purchased a new Hawkeye Spa. Now, where are you going to put it? Consider these guidelines before settling on a location for your spa.

First, the spa must be installed on a sturdy, flat surface. We recommend a concrete slab at least 4 inches thick. If you are placing the spa on a deck, it must have a load capacity of at least 90lbs per square foot. Consult a building inspector or a licensed contractor to ascertain whether your deck can withstand the added weight.

When properly installed, the cabinet frame will rest flat on the supporting surface. Do not attempt to shim the spa or place it on an otherwise unlevelled surface. Failure to place the spa on a level plane can cause the unit to distort, collapse or crack. Any such damage caused by improper installation will not be covered under the warranty.

All supporting surfaces should meet local and national building regulations and should be verified before installing the spa. If you choose to place the spa within a deck, it should be made accessible to service technicians. Please consult your Hawkeye dealer if you have any questions regarding the placement of your spa.

Electrical Wiring

*ALL ELECTRICAL WORK MUST BE DONE BY A LICENSED ELECTRICIAN
AND MEET THE NATIONAL ELECTRICAL CODE REQUIREMENTS!*

Please have your electrician refer to this section of the manual before installing the electrical service. The following guidelines are necessary for proper functionality of the spa.

- ❑ The spa must be set up with a dedicated service. Use of extension cords may create an electrical hazard and/or result in electrical damage which is not covered under the warranty.
- ❑ All 120-volt spas require a 20 AMP grounded (GFCI) outlet a minimum of five feet away from where the spa is to be located. Check with local building official for additional requirements.
- ❑ All 240-volt spas require a 50AMP GFCI breaker circuit. The spa can be set to run at 30 AMP by switching the high current jumper pin on the control board. At 30 AMPS, the heater and pumps cannot run simultaneously.
- ❑ All 240-volt systems require four wire conductors. Your electrician, depending upon location of the tub, will determine which wire size is required. We recommend at least an 8 AWG copper wire conductor be used. The circuit breaker panel should be a minimum of five feet away from where the spa is to be located. Check with the local building official for additional code requirements.
- ❑ Only copper wire may be used. Use of aluminum wire voids the warranty and may cause extensive damage to the equipment.

Electrical Wiring

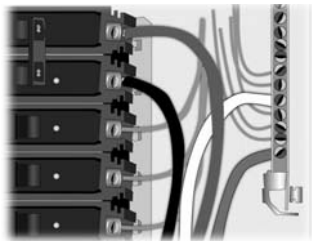
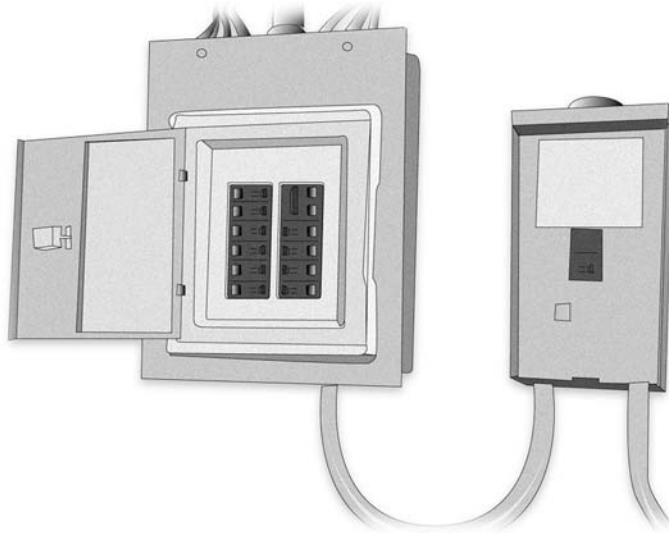

Electrical Box

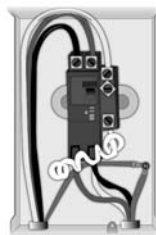

GFCI

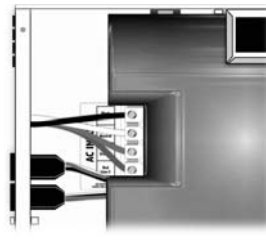

Pack Terminal Block

Note to the electrician:

Make a visual inspection for signs of miswiring.
Refer to supplied wiring diagrams.

Please see the following pages for common
GFCI configuration.

Electrical Wiring - Square D

240V GFCI SPA WIRING DIAGRAM FOR CERTIFIED ELECTRICIAN'S REFERENCE ONLY

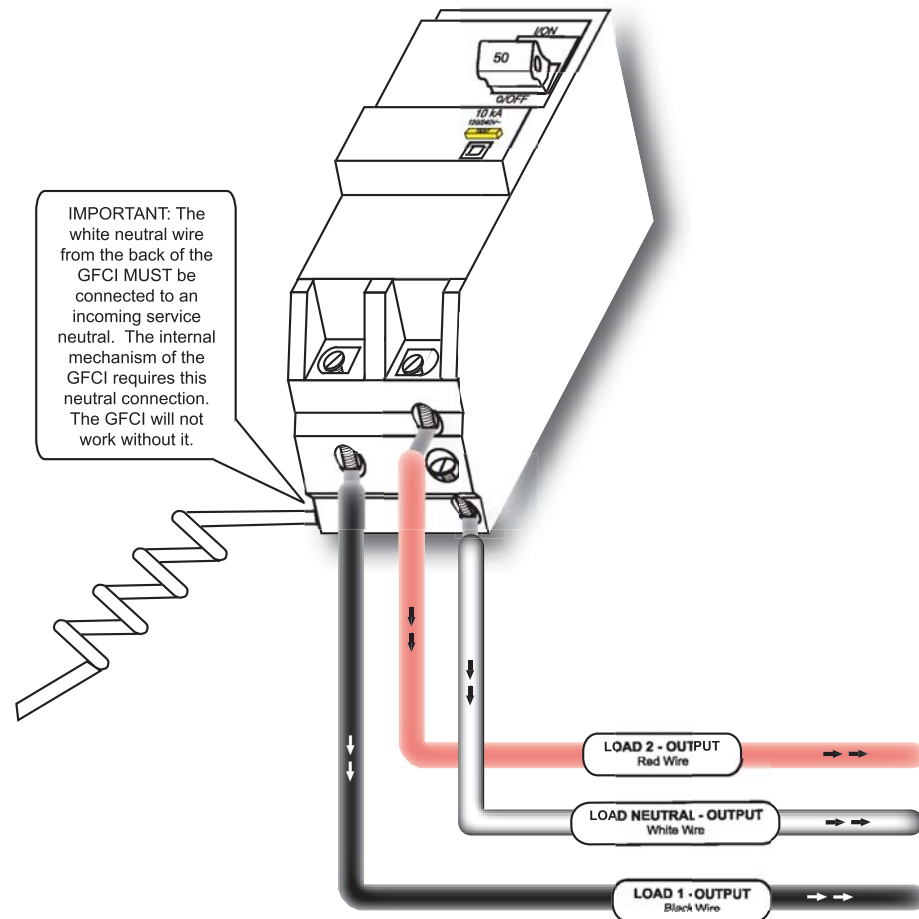

Electrical Wiring - Siemens

240V GFCI SPA WIRING DIAGRAM FOR CERTIFIED ELECTRICIAN'S REFERENCE ONLY

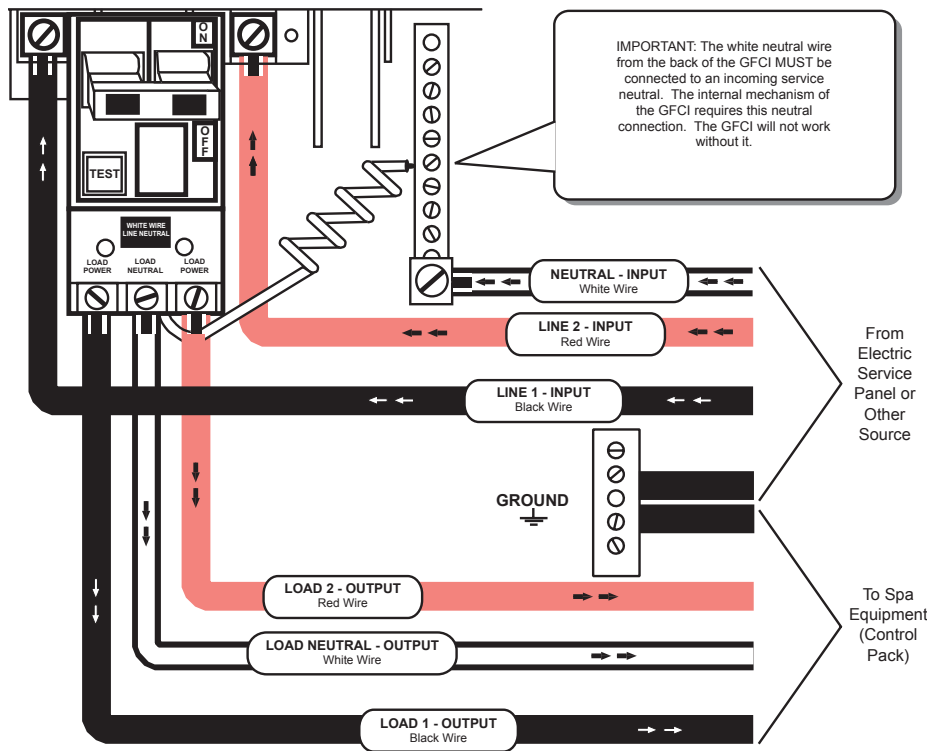

Filling the Spa

Refer to this section each time you fill your spa.

Now that you've picked a location and hired an electrician to install the electrical service, you are ready to begin filling the spa. But first there are few precautionary measures necessary before adding water.

- ❑ Make sure that the electrical service is shut off at the breaker. This will prevent damaging a pump if the spa is accidentally turned on without water in the system.
- ❑ Remove the cabinet panel directly below the topside controls to access the equipment compartment. On the pump(s) (refer to the "Components" section), check to make sure that the pipe unions are tight on each end. Before shipment from the factory, the unions are loosened to prevent damage if the spa should shift while in transit. These can be tightened easily by hand.
- ❑ Check that the external hose bib (located on the kick plate) is in the closed position by pushing in and turning to the right.
- ❑ Finally, fill the spa by placing a garden hose down inside the filter housing. On a dual-filter system, use the filter closest to the topside control panel. To access the filter housing, remove the telescoping assembly by turning counterclockwise. Next, remove the pre-filtration basket and filter. (For a schematic of the filtration assembly, please refer to the Components section) By filling the spa in this manner, you minimize the chances of trapping air within the pump system.
- ❑ Once the water level is approximately one inch above the highest jet (not including the neck-and-shoulder jets, if equipped), turn off the water supply. Reconnect the power at the breaker and test the spa for functionality. If three flashing dots are displayed on the topside controls - or for any other issues - refer to the troubleshooting section of this manual.

Operating Instructions

Now let's find out how the spa works!

Learning the controls on your spa will allow you to change the water flow, set maintenance cycles and monitor water temperature. When you first get the spa, do not be afraid to experiment with the controls. In fact, this may be the best way to learn all of your spa's capabilities.



Please note: Models pictured are equipped with most possible options.

To start Pump 1:



Press the "Jets 1" key to turn Pump 1 on low speed. Press the key again and Pump 1 will change to high speed. A third press will turn off Pump 1. If the pump is left running for 20 minutes, a built-in timer will automatically shut it off.

If your spa is equipped with a waterfall, it will be controlled by the "Jets 1" button.



The "Jets 1" triangular icon will appear on the display when Pump 1 is running.

To start Pump 2:



Press the "Jets 2" key to turn on Pump 2. Press the key again to turn off Pump 2. As with Pump 1, a built-in timer will automatically shut down Pump 2 after 20 minutes.



The "Jets 2" triangular icon will appear on the display when Pump 2 is running.

To start Pump 3:



Press the "Jets 3" key to turn on Pump 3. Press the key again to turn off Pump 3. As with Pumps 1 and 2, a built-in timer will automatically shut down Pump 3 after 20 minutes.



The "Jets 3" triangular icon will appear on the display when Pump 3 is running.

Operating Instructions

To turn on the light:

 Press the "Light" key to turn on the light. Pressing the key a second time turns off the light. A built-in timer automatically turns off the light after 2 hours.

LED Lighting:

To change lighting colors on spas equipped with LED, simply press the "light" button until the desired color is found. The light will turn on and off, each time cycling to a new color. Pressing the button repeatedly will activate alternating lighting patterns.



The "Light" indicator is displayed when the light is on

Note: If the light has been turned on, the filter cycle will not run until 45 minutes after the light has turned off.

Change the water temp:

 Press the "Up" or "Down" keys to increase or decrease the current temperature setting. The new temperature setting will remain on the display for five seconds as a confirmation of its new value.

 **Down**



The "Set Point" icon on the display will tell you that the temperature shown is the desired temperature of the water, not the actual temperature.

The temperature can be adjusted in 1 degree increments from 59° to 104°F (or from 15° to 40°C).

Operating Instructions

Programming Filter Cycles:

The system will automatically perform two filtration cycles per day, 12 hours apart. During a cycle, the following sequence is executed:

- 1) Pumps 2 and 3 run at high speed for one minute.
- 2) Pump 1 then runs at low speed for a predetermined number of hours
- 3) Ozone output is turned on

To set the length of filtration cycles (the amount of time Pump 1 will run), follow this procedure:



Press the "Light" key and hold for five seconds. The display will show "FXX", where "XX" represents the number of hours Pump1 will be running at low speed.



Use the "Up" and "Down" arrow keys to change the number of hours.

- "00" = no filtration
- "12" = continuous filtration



When the desired setting is reached, press the "Light" key one final time to begin the filter cycle. This will be the time of day that the first cycle will run. To program a specific time for the filter to run, you will need to perform the above steps at that particular hour. If you do not want the filter cycle to engage immediately, do not press the "Light" key at the end of the programming sequence.

The "Filter Cycle" triangular icon will appear on the display when a filter cycle is running.

▼ *Note: After a power failure, the filter cycle duration will return to its default value (2 hours). In this case, the first filter cycle will start 12 hours after power has been restored.*

Operating Instructions

Water heater auto start:

When the water temperature is 1°F lower than the set point, the heater will run until the water temperature reaches the set point, plus 1°F.



The "Heater On" triangular icon will appear on the display when the heater is on.

Economy Mode:



The economy mode is most commonly used when the spa is not to be used for extended periods, such as vacations.

Press the "Econo" key to put the system in Economy Mode. In this mode, the system will maintain the water temperature 20°F below the programmed set temperature and the display will alternate between temperature and "Econ."

The spa will heat to its manually set temperature during the filter cycles.

Balancing Your Spa's Water

To obtain the highest level of enjoyment from your new Hawkeye Spa, it is essential that the water be properly maintained.

Ozone Purification System

Hawkeye's ozone purification system is an excellent cleaning method, aimed at reducing the amount of chemicals needed to treat the spa's water. Best of all, it runs automatically! The system is an ozone-based purifier that eliminates the majority of microorganisms in the water.

If you chose to locate your spa indoors, we recommended that the area be properly ventilated.

General Water Chemistry

The chemistry of spa water changes rapidly. High water temperatures, aeration of the water and body chemistry of spa users can significantly affect these fluctuations. In addition, the extremely high body-to-water ratio in the average spa demands greater chemical treatment. For example, five people in a

500-700 gallon spa is equivalent to about 250 people in an average size (25,000 gallon) pool.

Furthermore, high water temperatures provide an ideal environment for the growth of algae and bacteria.

Due to rapid changes in the water chemistry, spa water should be tested daily with a test kit available from your dealer.

Sanitizers

Bromine and chlorine are the most widely used disinfectants for maintaining properly balanced water. Bromine is normally preferable because of its less intrusive odor and greater warm-water resiliency. Both chlorine and bromine, as well as other sanitation options are available from your dealer in various forms.

Follow the instructions on the sani-

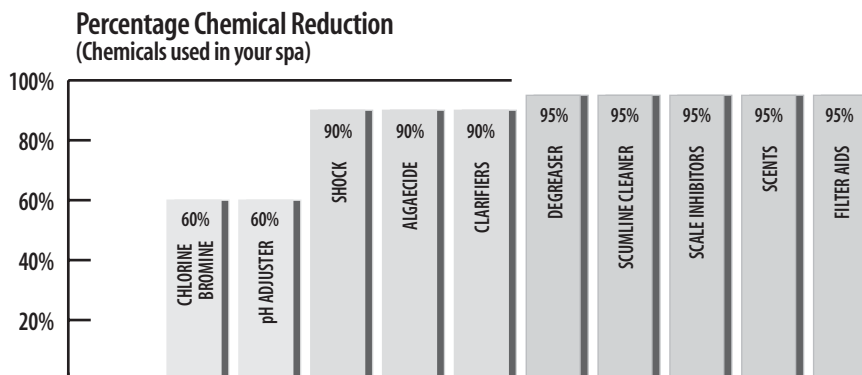

Balancing Your Spa's Water

tizer package for proper amounts. **CAUTION!** Never place sanitizers directly on the spa shell as it will damage the surface. Use a dispenser or place the sanitizer tablets in the filter basket.

Consult your dealer for the proper amounts required to disinfect your spa's water. Remember, spas using an ozone purification system will require up to 60% less chlorine or bromine.

pH Balance

pH (potential Hydrogen) is a measure of your water's acidity or alkalinity (basicity). The pH scale runs from 0-14. Substances measuring pH 0-6.9 are considered acidic. Substances measuring pH 7 are considered neutral. Substances measuring pH 7.1-14 are considered alkaline (basic). The ideal pH for spa water is pH 7.2-7.8, or slightly alkaline. Water with a pH above 7.8 can produce scales, become excessively cloudy and reduce the effectiveness of sanitizers. Chemicals for maintaining pH are available from your dealer.

Total Alkalinity

Total alkalinity refers to the amount of all alkaline salts in the water. Measuring total alkalinity means measuring the water's ability to buffer itself against changes in pH.

Thus, pH and total alkalinity are related, but they are not one in the same. Total alkalinity of spa water should be maintained within the range of 80-120 parts per million (ppm). This will keep the pH stable and help prevent against scaling and cloudy water. Always be sure your total alkalinity is properly adjusted before attempting to adjust your pH. Chemicals used to maintain total alkalinity are available at your dealer.

One last thought about water chemistry

Water chemistry is an important part of protecting and enjoying your spa. For specific questions about water maintenance, consult your dealer. Many dealers offer computerized water testing to help you with any problems that may occur. Additionally, we recommend you have your water tested periodically by your dealer, as your dealer's more sophisticated testing methods and greater array of tests may help you foresee a condition which may not be detectable with your customer test kit.

General Maintenance

Your Hawkeye Spa will provide years of use when operated and maintained properly. The following operating and maintenance instructions are very important and should be followed carefully.

Maintenance Cycles

There is very little maintenance necessary on the pump, electronic controls or heater. The pump and heater should be operated a minimum of two, 2-hour cycles per day for the cleaning, filtering and heating of the water. These two cycles are programmed into the electronic controls and begin when power is applied to the spa. These cycles occur every twelve hours (240V only).

GFCI Maintenance

The G.F.C.I. should be tested once a month. Testing of the G.F.C.I. should be in compliance with the G.F.C.I.'s manufacturer.

Should the G.F.C.I. fail:

- ❑ DO NOT use the spa as this indicates there is a possibility of an electrical shock.
- ❑ Disconnect power at the breaker until the fault has been identified and corrected by a qualified electrician or your spa service technician.

Heating Time

The length of time required to heat your spa to the desired temperature will vary depending on the season, water temperature, location and other environmental factors.

Approximate heating time is about 3-6 degrees per hour for 240V spas and 1-2 degrees per hour for 120V spas.

Hawkeye recommends using an insulated vinyl cover to minimize heat loss and to protect your spa when not in use. Covers are available from your local Hawkeye Spas Dealer.

Cleaning the Filter

The filter should be removed and cleaned every two to three weeks with a high-pressure garden hose, and every two to three months with a filter cleaner. To access the filter, remove the telescoping assembly by turning counterclockwise. Next, remove the pre-filtration basket and pull out the filter.

CAUTION! DO NOT USE A PRESSURE WASHER TO CLEAN YOUR FILTER!

Any debris dropping into the spa should be removed immediately from the spa, as they may cause damage to the pump or the other equipment.

You should also replace the filter about once per year, depending on use.

General Maintenance

Changing the Water

Maintaining proper water chemistry in the spa is of the utmost importance. Refer to the "Balancing Your Spa Water" section for complete details.

It is suggested that you maintain your water according to the recommendation of your dealer and change your water once every four months depending on the area and the amount of usage.

To remove a water line, use a mixture of ammonia and water in a spray bottle. Use of soap products will increase foam retention.

DO NOT USE AN ABRASIVE CLEANER OR HAND BRUSH!

Draining the Spa

There are three ways to drain your spa:

- 1) External Drain Valve - Refer to the "Components" section for an explanation of use.
- 2) Reverse Siphon Method - Place a hose into the spa water and attach to a faucet. Fill the hose with water from the faucet and detach it from the water source. The water from the tub should now flow through the hose and drain down to the bottom.
- 3) Submersible Pump - A small electrical pump may also be used. If you use a submersible pump, be careful

not to scratch the spa's surface.

Cabinetry Maintenance

Your Hawkeye spa cabinet is constructed with a hand-made mahogany or maintenance-free skirting. We recommend restaining the mahogany cabinets at least once a year. Refer to the "Parts" section for which stain to use. For a weathered mahogany look, apply the stain with a soft cotton cloth.

You can also preserve your mahogany cabinet by treating it with boiled linseed oil. Use a mixture of 3 parts linseed oil to 1 part paint thinner. This will prevent the mahogany from splitting if done once per year.

The synthetic cabinets can be cleaned with a mild soap-and-water solution applied with a soft brush.

In locations with extreme weather conditions, you may need to clean/re-stain your cabinetry more often.

General Maintenance

Checking for Leaks

It's always a good idea to check your spa for leaks about once a month.

This small preventative task can allow you to foresee a problem before it develops. To check for leaks, remove the access panel and look at the base of the spa for any accumulated water. Also, check the plumbing for leaks or drips.

Overall Maintenance Checklist

To receive many years of enjoyment from your Hawkeye Spa, remember the following points:

- Maintain proper water chemistry.**
- Keep the spa covered when not in use.**
- Clean the filter every two or three weeks. Replace at least one per year.**
- Test the GFCI breaker once per month.**
- Make sure the spa is situated on a solid, sturdy base.**
- Change the water approximately every four months.**
- Open the equipment compartment and check for leaks every few months.**
- Stain or clean your cabinet as needed.**

Troubleshooting

Use this section to diagnose and repair common problems.

3 Flashing Dots

If three flashing dots are displayed on the topside controls, reset the GFCI breaker to see if this solves the problem. If not, check that each filter is clean and that the water level is at the proper height. If the 3 flashing dots persist, one of your pumps may be air-locked. To alleviate this problem, you will need to bleed each pump. Use the following procedure:



- 1) Remove the cabinet panel directly below the topside controls to access the equipment compartment.
- 2) Locate the pumps and pump bleeders (see "Components" section)
- 3) With the spa running, loosen the bleeder valve and let the air "hiss" out. Water will most likely drip out. Once water begins to pour out heavily, tighten up the bleeder again.
- 4) Do this for each pump and see if the display returns to normal.

If the problem persists, you will need to contact your dealer for service.

Flashing Water Temperature



If the water temperature display is flashing on the topside controls, your spa's water temperature has reached 112°F (44°C). DO NOT enter the water!

- 1) Remove the spa cover and allow the water to cool down.
- 2) Reset the GFCI breaker.
- 3) The system will reset itself when the water reaches 109°F (43°C).

DO NOT ENTER THE WATER UNTIL THE TEMPERATURE IS 104°F OR LESS!

You will need to call your dealer for service if this problem persists.

Troubleshooting

Flashing Filter Cycle Indicator

An irregularly flashing Filter Cycle indicator could mean one of two things.



1) The system has stopped filtering after three hours because the water temperature has exceeded the set point by more than 2°F (1°C). If the temperature cools down before the scheduled end of the cycle, filtering will resume for the remainder of the programmed cycle duration. To cool the spa, try removing the cover.

Note: After a power failure, the first filter cycle will start 12 hours after power has been restored.

2) There has been a 40 minute filter-cycle timeout. If you turn on a pump or press any function on the topside controls during a filter cycle, the cycle will be interrupted and will only resume 40 minutes after you (or the system) have turned the last active output off. In this case, an irregularly flashing "Filter Cycle" indicator means that the system has stopped filtering because the filter cycle has been interrupted by the manual activation of an output. To allow the filtration process to continue, you should turn off all functions and wait 40 minutes for the cycle to begin again.

Replacing the Light Bulb

If the underwater lighting does not respond when turned on, the bulb may have burned out. You will need to replace the bulb from underneath the spa. Make sure that power to the spa is turned off at the breaker. Remove the cabinet panel that is closest to the location of the light. Reaching underneath the spa, you should be able to grasp the light fixture and remove it from its housing. This is done by turning the fixture counterclockwise. Replace the bulb and test for functionality.

If the bulb still does not work, trace power wire from the light back to the control pack. Make sure it is plugged in.

Troubleshooting

Spa Is Not Heating

If the spa does not seem to be heating the water, carry out the following tests to correct the problem:



- 1) Verify that nothing is flashing on the display (flashing dots or water temperature). If the display is flashing, refer to the beginning of the troubleshooting section.
- 2) If nothing is flashing, attempt to raise the temperature set point with the "Up" key. Now check to see if the heater indicator appears on the display. It will flash when more heat has been requested, and remain lit when the heater has started running.
 - o If the heater indicator does not light up, reset the GFCI breaker and repeat step 2. If this does not solve the problem, contact your dealer for service.
 - o If the heater indicator does light up, but the spa still does not heat, contact your dealer for service.

Pump 1 Not Working

If Pump 1 does not work:

- 1) Check to see if there are three flashing dots on the top side control. If this is the case, refer to the beginning of troubleshooting section.
- 2) If the display is not flashing and the spa is getting power, try resetting the breaker. If still nothing works, call your dealer for service

Pumps 2 or 3 Not Working

If a pump other than Pump 1 is not working, check to see if the pump icon is present on the topside when the pump is running. If the icon is present but there is no output, you should attempt to bleed the air from the unresponsive pump. Follow this procedure:

- 1) Remove the cabinet panel directly below the topside controls to access the equipment compartment.
- 2) Locate the pumps and pump bleeders (see "Components" section)

Troubleshooting

- 3) With the spa running, loosen the bleeder valve and let the air hiss out. Water will most likely drip out. Once water begins to pour out heavily, tighten up the bleeder again.
- 4) Check for functionality of this pump.

If the pump icon is not present on the topside controls when the pump button is pressed, or the preceding bleed procedure did not remedy the problem, you will need to contact your dealer for service.

Low Water Pressure/Jets Not Working

If you are experiencing low water pressure in certain areas of the spa, first make sure that the jets in that section are in the open position. This is done by turning the jet face counterclockwise. Also, if your spa has a diverter valve on the top rail, try changing its position to direct more pressure toward that side of the spa. Finally, you may need to bleed the corresponding pump. Determine which pump powers the section with low pressure ("Jets 1" on the topside uses Pump 1, etc.). Follow the procedure for bleeding the pump as outlined previously ("Pumps 2 or 3 Not Working!").

Circuit Breaker Tripping

If your GFCI breaker trips and will not let you use the spa's functions, you can determine the root of the problem through process of elimination.

- 1) First, turn down the set temperature on the topside controls to deactivate the heater. If the breaker does not trip with the spa temperature set to the lowest point, you may have a bad heater element and should contact your dealer for service. If the breaker still trips, continue on to the next step.
- 2) With the breaker turned off, remove the panel below the topside control to access the equipment compartment.
- 3) On the left side on the control pack, you will see a series of multicolored plugs aligned vertically.
- 4) Remove the first plug to disconnect that component.
- 5) Reset the breaker and see if the spa will power up without tripping the breaker. If it will not, repeat steps 3 and 4, disconnecting each component individually until the breaker does not trip.
- 6) Once the breaker remains on, trace the plug of the last component disconnected back to its source. This is the part that will need to be looked at for service.

● **Checking the fuses**

If you feel that you may have blown a fuse, you will need to open the control pack. First, disconnect power to the spa at the breaker. Now, access the equipment compartment directly below the topside controls. Next, disconnect power to the spa at the breaker and open the control pack. Use the wiring schematic on the inside cover of the control to check which fuses power which components.

Pumps making noise

If your pumps are making a loud, rattling noise, one or more of the mounting bolts may have come loose. In the equipment compartment, check that each bolt on the pump is tight enough to prevent movement or shaking. If this does not solve the problem and water pressure is affected, you will need to contact your dealer for service.

No display on the topside control

If you find that the topside control is blank, but that there is still power to the spa, you will need to replace the F4 fuse on the control board.

- 1) With the spa turned off at the breaker access the equipment compartment directly below the topside controls.
- 2) Open the control pack and locate the wiring schematic on the inside cover.
- 3) Look for the F4 fuse on the schematic and then replace the corresponding fuse on the board.

Ozonator Not Working

This is a common misconception. The ozone generator is programmed to run independently and will not run until 45 minutes after the last spa function was turned off. Therefore, if you recently used the spa, or even turned on the light, the ozone generator will not come on until 45 minutes have elapsed. You will see a purple LED in the generator's display when it is operating.

If the ozone generator does not run after 45 minutes have passed, you will need to contact a dealer for service.