

BL-45

TROUBLESHOOTING GUIDE

BL-45 SPA-SIDE CONTROL SYSTEM

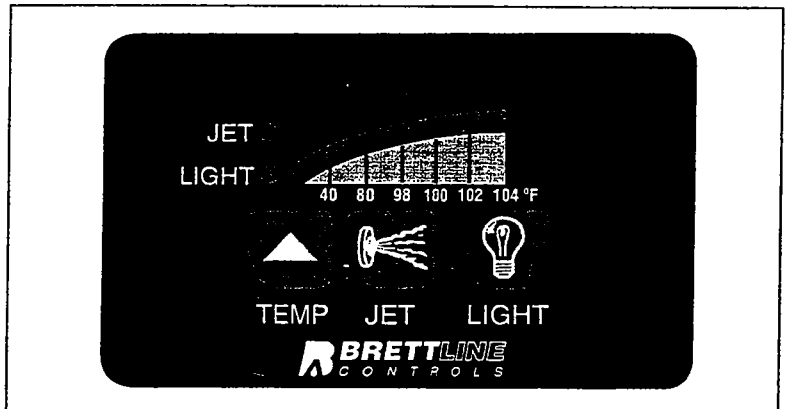

TABLE OF CONTENTS

Introduction	1
Flow chart	2
Tools required	2
Recommended replacement parts	2
Identifying the problem	
• Troubleshooting indicator lights	3
• Power up system check	4
• Spa-side control operation	4
Spa-Side control system description	5
System wiring schematic	6
Self diagnostics	
• Error codes	7
Troubleshooting specific problems	
• Nothing operates	9
• Erratic operation	10
• Control trips GFCI	10
• Pump high speed (JETS) will not operate	11
• Pump low speed (filter) will not operate	12
• Filtration cycle not working properly	13
• Ozone generator output will not operate	13
• Spa light will not operate	14
• Water temperature too hot or spa overheats	15
• Heater will not operate	16
• Bargraph temperature display indicates incorrect water temperature	17
• Spa will not maintain set water temperature	17
• Bargraph temperature display does not work	17
Temperature vs Resistance table	18
• Temperature sensor and High limit sensor checkout procedure	18

BRETT AQUALINE
TECHNICAL SUPPORT
888-644-7727

INTRODUCTION

This Troubleshooting Guide has been designed for easy simple step-by-step problem solving.

It is important to identify all of the possible causes of the problem before making a final diagnosis. What you see at first is usually a symptom of the problem, not necessarily the problem itself.

Read the whole troubleshooting procedure related to what you are testing prior to doing the test. This will help give you a clearer overall view and avoid a costly mis-diagnosis.

TO PREPARE FOR THE SERVICE CALL:

- Be sure you fully understand how the system operates. Read the information contained in IDENTIFYING THE PROBLEM page 3.
- Use standard testing devices, such as:
 - Volt OHM Meter (VOM)
 - 6 inch Test wire with alligator clips
 - Accurate thermometer
 - Clamp-on ammeter
- Take necessary test and replacement parts:
 - Spa-side control panel (for testing / replacement)
 - BL-45 Relay circuit board (for testing / replacement)
 - BL-45 Control circuit board (for testing / replacement)
 - Recommended replacement parts kit

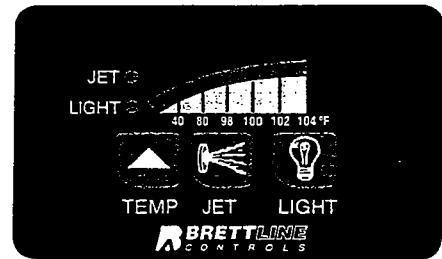
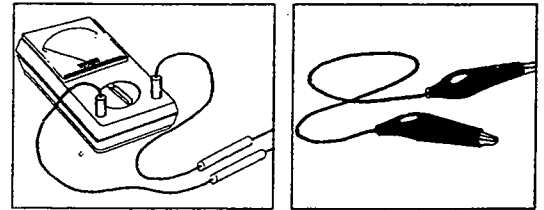

BL-45 Spa-Side control panel
P/N 24-4702-05R

RECOMMENDED REPLACEMENT PARTS:

- Pump motor
- Pump motor fuse, 20 amp - P/N 37-1030
- Light fuse, 3 amp - P/N 37-0121
- Transformer, 120V, 2 amp - P/N 37-1019
- Transformer fuse, 3 amp - P/N 37-0121
- Heater assembly - P/N 22-5019
- Pressure switch - P/N 34-0110TDI
- Temperature sensor - P/N 38-0400-SS-A
- Hi-limit sensor - P/N 38-0399-SS-A
- Spa light bulb - P/N 37-0101F

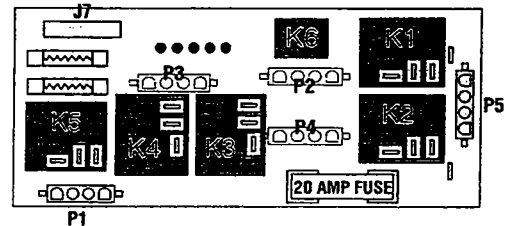

Relay circuit board P/N 34-5021

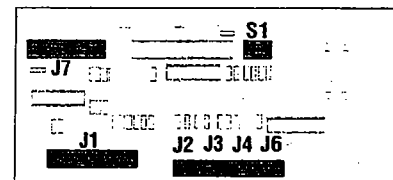

Control circuit board P/N 34-5019

**BRETT AQUALINE
TECHNICAL SUPPORT
888-644-7727**

FLOW CHART

The Flow Chart below will assist you in the proper troubleshooting sequence. It also outlines the "most likely cause" other than equipment failure.

CHECK CIRCUIT BREAKERS

CHECK GFCI

If GFCI trips (erratic tripping) - Check for correct GFCI installation and Control trips the GFCI (page 10) →

CHECK RELAY CIRCUIT BOARD POWER

	OK	NOT OK
Input power - Relay K1 & K3 common	120/240 VAC	Check input wiring
Fuse - F1, F2 & F3	0 ohms	Replace fuse

SPA WATER TEMPERATURE

40°F - 104°F

SPA-SIDE CONTROL PANEL / TOUCH PADS / INDICATOR LIGHTS / BARGRAPH TEMPERATURE DISPLAY / RELAY CIRCUIT BOARD

With power ON - The Bargraph temperature display should indicate the spa water temperature, or if the heater is operating, the LED's will sequentially illuminate up to the current spa water temperature.

If two LED's on the Bargraph temperature display illuminate (not sequentially) an Error condition exists.

If all LED's on the Bargraph temperature display blink ON and OFF, an overheat condition exists.

PROCEDURE	STATUS SPA	SPA-SIDE CONTROL	RELAY CIRCUIT BOARD	ACTION IF NOT OK
Press JET once	Low speed pump ON	-	Filter T/S indicator light ON	Check for broken wire or loose connection at P2, J1 & J7
Press JET again	High speed pump ON	Jet indicator light ON	JET T/S indicator light ON	Check for broken wire or loose connection at J1 & J7
Press LIGHT	Spa light ON	LIGHT indicator ON	Light T/S indicator ON	Check for broken wire or loose connection at P4 Check light bulb
Press and hold TEMP until 104°F	-	104°F displayed	Heater T/S indicator light ON (if the heater is operating)	Check for broken wire or loose connection at J2, J3, J4

OK

Check temperature sensor, wiring & J2 receptacle connection

Check high limit sensor, wiring & J3 receptacle connection

Check pressure switch, wiring & J4 receptacle connection

NOT OK

Repeat above with Test Spa-side control panel

OK

Replace Spa-side control panel

NOT OK

Repeat above with Test Relay circuit board

OK

Replace Relay circuit board

NOT OK

Repeat above with Test Control circuit board

IDENTIFYING THE PROBLEM

To avoid mis-diagnosis and better understand how the system operates, read and familiarize yourself with the information contained in TROUBLESHOOTING INDICATOR LIGHTS, POWER UP SYSTEM CHECK and SPA-SIDE CONTROL OPERATION instructions.

The BL-45 incorporates a series of troubleshooting indicator lights that will assist you in rapidly identifying specific problem areas.

TROUBLESHOOTING INDICATOR LIGHTS

When attempting to isolate a specific problem, the troubleshooting indicator lights will provide an accurate means to determine if the problem is in the electronics or somewhere after the circuit board outputs.

In example, if the jets do not operate, press the JET touch pad a few times while viewing the jet Troubleshooting Indicator light and Spa-side control jet indicator light.

- If the jet indicator lights turns ON and OFF with each push of the JET touch pad, the spa-side control and circuit boards are operating properly. The problem has been isolated to:
 - The pump motor
 - Pump fuse
 - Pump wiring
 - Relay output
- If the indicator light does not illuminate, the problem has been isolated to:
 - Loose spa-side control connection J1 on Control circuit board.
 - Defective spa-side control
 - Defective Control circuit board or Relay circuit board
 - Loose connection J7 Control circuit board or J7 Relay circuit board

The troubleshooting indicator lights are located on the relay circuit board, contained in the Control Module. Each of these lights are labeled to correspond with their output function as follows:

- LD1 - Spa Light
- LD2 - Filter (pump low speed)
- LD3 - Jet (pump high speed)
- LD4 - Heater
- LD5 - Hi-limit (normally on)

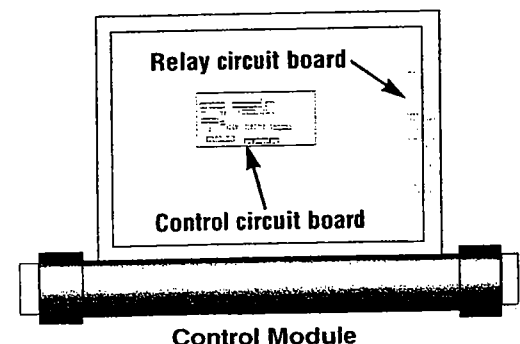
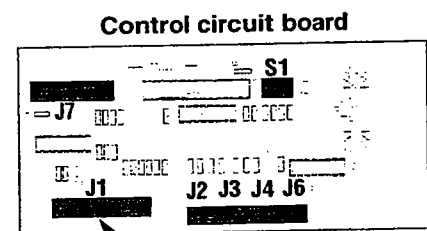
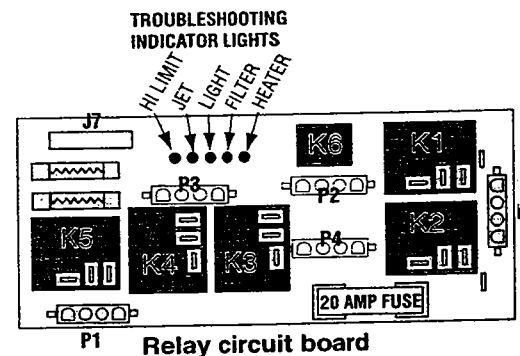
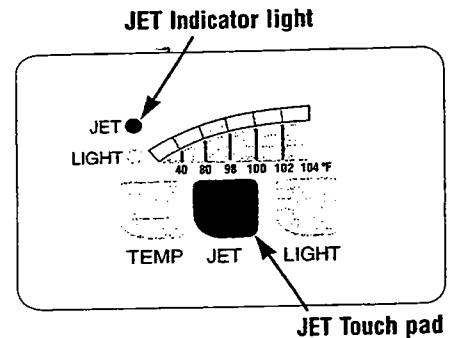

IDENTIFYING THE PROBLEM

POWER UP SYSTEM CHECK:

- When power is first applied to the unit, all LED (Light Emitting Diodes) segments of the spa-side bargraph display will illuminate for approximately three seconds. Confirm operation of all LED segments prior to proceeding.
- If there is not a service disconnect close to the spa, the Power Up System Check may be initiated by disconnecting and reconnecting the spa-side controller.

SPA-SIDE CONTROL OPERATION

After power is applied to the spa and the Power Up System Check is complete, the bargraph temperature display should indicate the current water temperature, or if the heater is operating the LED's will illuminate sequentially up to the current temperature.

- **TEMPERATURE SETTING** - Press and release the TEMP touch pad, the set water temperature will be displayed for approximately 4 seconds on the bargraph temperature display.

- To increase set water temperature, press TEMP while set water temperature is displayed. Each press increases the set water temperature (temperature settings are 40, 60, 83, 86, 89, 92, 95, 98, 99, 100, 101, 102, 103 and 104°F).
- The temperature display only indicates 40, 80, 98, 100, 102 and 104°F. Therefore it is important that each press of TEMP be counted to determine the actual set temperature. For example, if the set temperature is 100°F and a temperature of 103°F is desired, press the TEMP touch pad three times. Although the display is showing 102°F, the actual set temperature is 103°F.
- If the TEMP touch pad is pressed and held down, the temperature setting will change rapidly and stop at 104°F. Press again and temperature setting will revert back to 40°F.

- **JET OPERATION** - Press and release the JET touch pad, the pump should operate in low speed. Press again and the pump should operate in high speed. Press again and the pump should turn OFF.

- The JET indicator light should illuminate whenever the pump is operating in high speed.
- The jets operate for a period of thirty minutes and then automatically turn OFF.
- If the pump is operating in a programmed filter cycle or a heating cycle, the first press of the JET touch pad will activate the pump high speed.

- **LIGHT OPERATION** - Press and release the LIGHT touch pad and the light should turn ON. Press again and the light should turn OFF.

- The LIGHT indicator should illuminate whenever the spa light is ON.
- The light will operate for four hours, then automatically turn OFF.

Bargraph Temperature Display

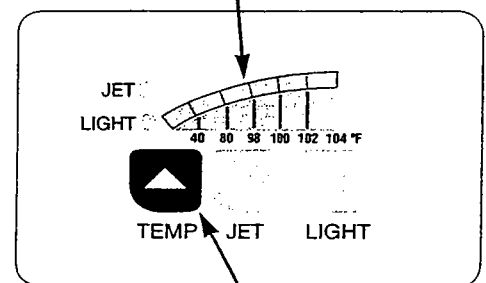

Temperature setting touch pad

JET Indicator Light

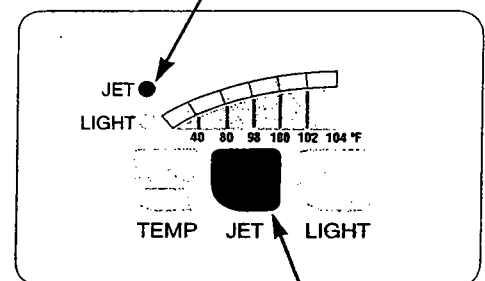

JET Touch pad

LIGHT Indicator

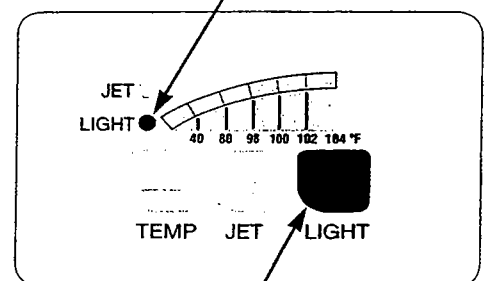

LIGHT Touch pad

SPA-SIDE CONTROL SYSTEM DESCRIPTION

The BL-45 spa control system consists of a Spa-side Control Panel and a Control Module with a Relay circuit board and a Control (logic) circuit board.

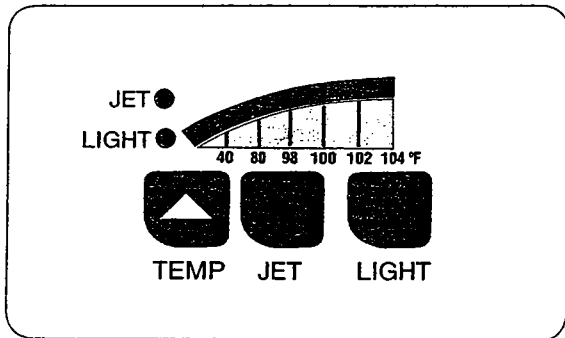

Spa-side control panel

The Spa-side control panel contains the following components:

Bargraph temperature display

Six LED's - Indicate current and set temperature as well as system Error codes

Indicator lights

Jet light illuminates when jets are ON
Light light illuminates when Spa light is ON

Touch pad controls

TEMP - Temperature setting
JET - Activates jets and pump low speed
LIGHT - Turns spa light ON and OFF

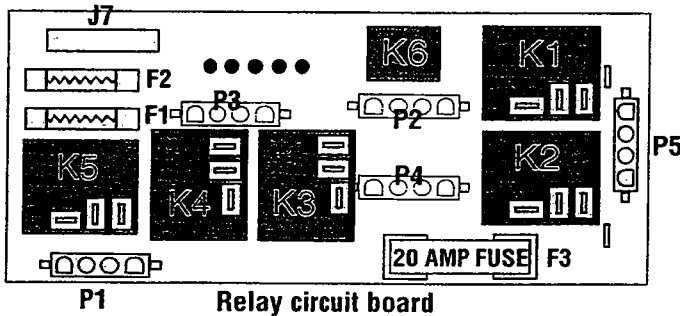

Relay circuit board

The Relay circuit board contains the following components:

Relays

K1 Hi-limit
K2 Hi-limit
K3 Heater
K4 Pump high speed (jets)
K5 Pump low speed (filter)
K6 Spa light

Troubleshooting indicator lights

LD1 Spa light
LD2 Filter (pump low speed)
LD3 Jet (pump high speed)
LD4 Heater
LD5 Hi-limit (normally ON)

Fuses

F1 Transformer (3 amps)
F2 Spa Light (3 amps)
F3 Pump fuse (20 amps)
Note: Some units may have a single 3 amp fuse (F1) for the transformer and spa light (instead of 2 fuses, F1 & F2)

Connection ports

P1 Transformer
P2 Pump
P3 Ozone receptacle
P4 Spa light receptacle
P5 Input power receptacle
J7 Control circuit board

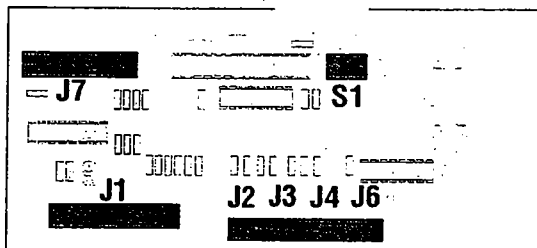
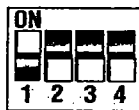

Control circuit board

The Control (logic) circuit board contains the following components:

Filter cycle switches S1

SW1, SW2, SW3 and SW4
(used for setting filter cycles)

Connection ports

J1 Spa-side control panel
J2 Temperature sensor
J3 High limit sensor
J4 Pressure switch (flow)
J6 Not used
J7 Relay Circuit board

SYSTEM WIRING SCHEMATIC

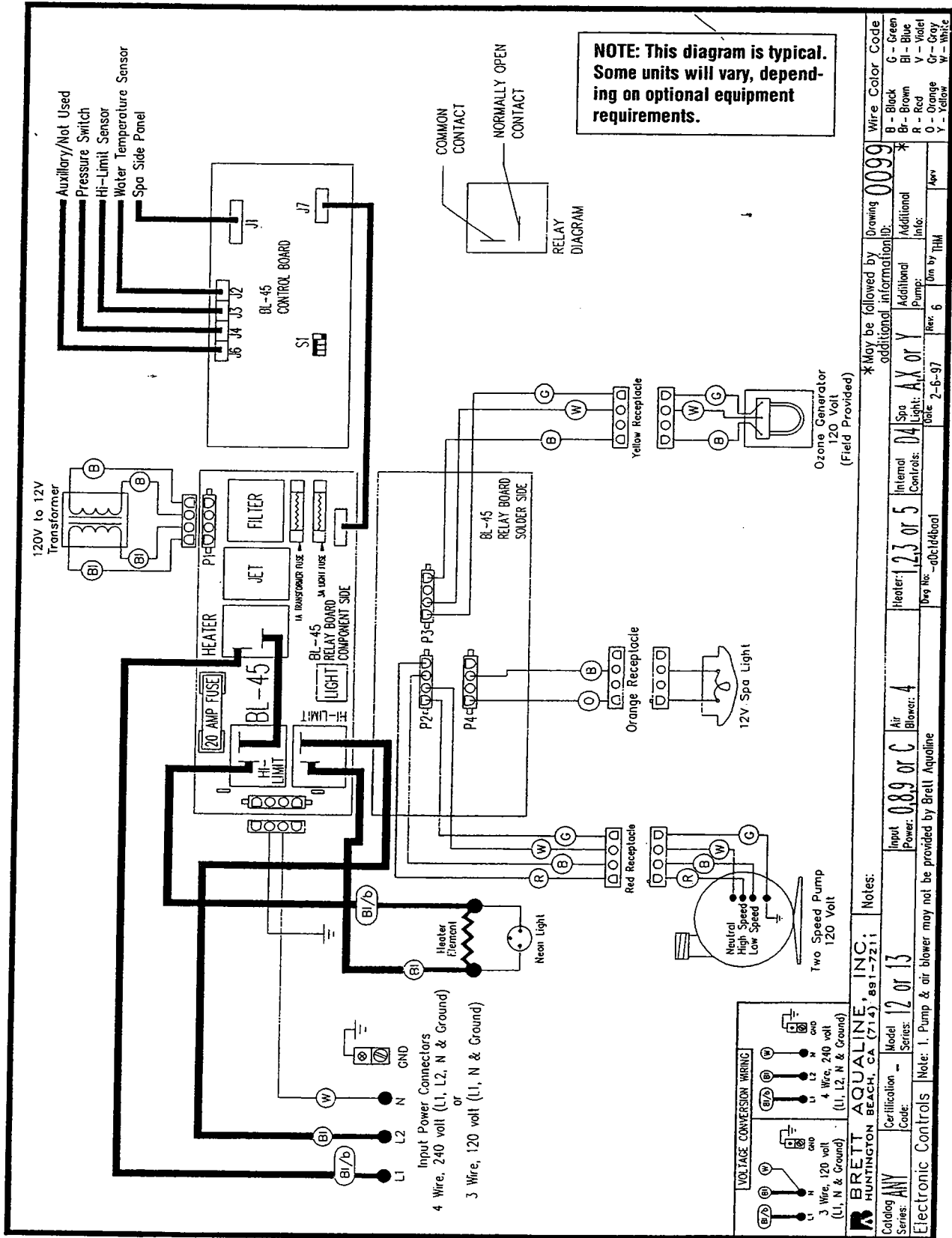

*May be followed by additional information ID: 0099	
Heater: 1, 2, 3 or 5	Spa Light: 04
Internal Controls: 05	Spa Light: 04
Input Power: 0.89 or C	Air Blower: 4
Model: 12 or 13	Series: 12 or 13
Code: ANY	Code: ANY
Electronic Controls Note: 1. Pump & air blower may not be provided by Brett Aqualine	
Rev: 6	Rev: 6
On by THM	On by THM
App	App

ERROR CODES

SPA-SIDE ERROR CODES:

The BL-45 incorporates a variety of diagnostic and protection features. In the event of a system error, one of the error codes listed below may be displayed on the spa-side bargraph display.

ALL LED's BLINKING

The spa water temperature has exceeded 118°F (48°C), causing the the heater to automatically shut off.

Check the spa and correct:

- Dirty filter cartridge
- Closed plumbing valve
- Plumbing obstruction
- Low water level
- Loose wire or Temperature sensor disconnected. Check J2 on the Control circuit board
- Temperature sensor not properly installed (refer to page 15 WATER TEMPERATURE TO HOT OR SPA OVERHEATS)

To Reset Heater:

When the water temperature is below 104°F (40°C), press the TEMP touch pad to reset the heater.

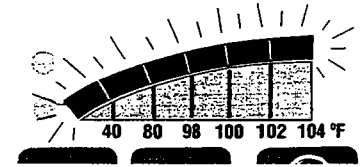

Control circuit board

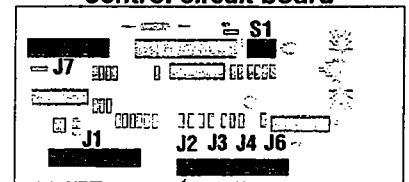

Temperature sensor connection J2

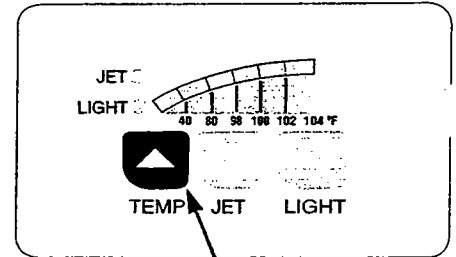

Press TEMP to reset heater

RED (104) AND ORANGE (98) LED's ARE ILLUMINATED

The Pressure Switch is not measuring adequate water flow to permit heater operation.

Check the spa and correct:

- Dirty filter cartridge
- Closed plumbing valve
- Plumbing obstruction
- Low water level
- Pump not primed
- Loose wire or Pressure switch disconnected. Check J4 on the Control circuit board
- Pressure switch out of adjustment or defective

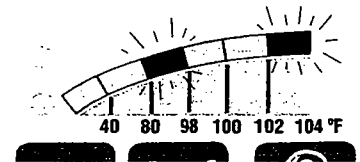

Control circuit board

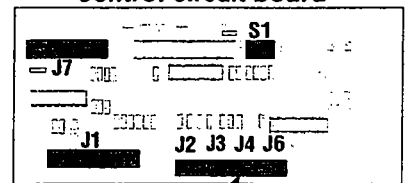

Pressure switch connection J4

TWO RED (102 & 104) LED's ARE ILLUMINATED

The water temperature-regulating sensor is out of calibration, shorted or disconnected (open).

- Check the sensor connection J2 to the Control circuit board for loose connection.
- If the sensor connection is good, check the sensor - if out of specification, replace the sensor assembly.
- To check the sensor, remove the sensor plug (J2) from the Control circuit board and measure the resistance between the plug's center terminal wire and the black wire. Compare results with TEMPERATURE vs RESISTANCE table page 18.

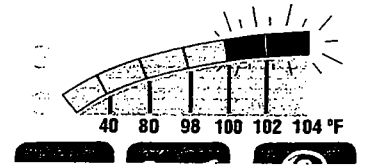

Control circuit board

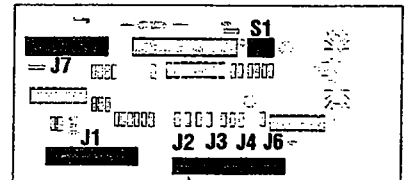

Water temperature sensor connection

RED (104) AND ORANGE (100) LED's ARE ILLUMINATED

The water temperature high-limit sensor is out of calibration, shorted or disconnected (open).

- Check the high limit sensor connection J3 to the Control circuit board for loose connection.
- If the sensor connection is good, check the sensor - if out of specification, replace the sensor assembly.
- To check the sensor, remove the sensor plug (J3) from the Control circuit board and measure the resistance between the plug's center terminal wire and the black wire. Compare results with TEMPERATURE vs RESISTANCE table page 18.

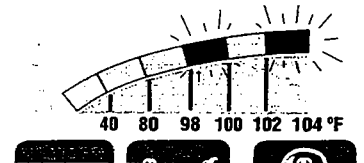

Control circuit board

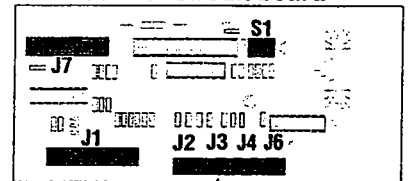

High limit sensor connection

TROUBLESHOOTING SPECIFIC PROBLEMS

NOTHING OPERATES:

- Check circuit breaker supplying power to the spa.
- Check spa-side control connection, J1 on the Control circuit board.

Turn power ON and check for correct input power supply:

- Check input power supply at relay K1 common, K3 common, and the neutral wire as shown.
- On 240V systems be sure to check for 240V, NOT just 120V to neutral.

If the correct input power is not measured:

- Correct the problem before proceeding.

Check 20 Amp fuse:

- With the power OFF, use a OHM meter to check continuity of the fuse (located on the Relay circuit board). If OPEN (infinite resistance) replace fuse.

Check 1 amp Transformer fuse on Relay circuit board :

- With the power OFF, use a OHM meter to check continuity of the fuse (located on the Relay circuit board). If OPEN (infinite resistance) replace fuse.
- If the fuse is good, connect a test transformer to P1 on the Relay circuit board and determine if the transformer is defective.
- If the test transformer does not correct the problem, replace the Relay circuit board.

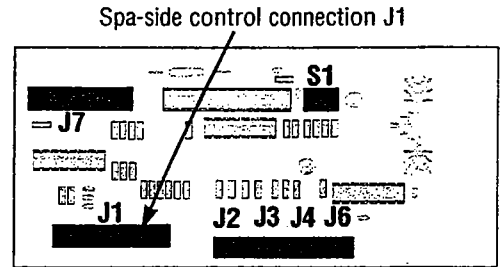

Control circuit board

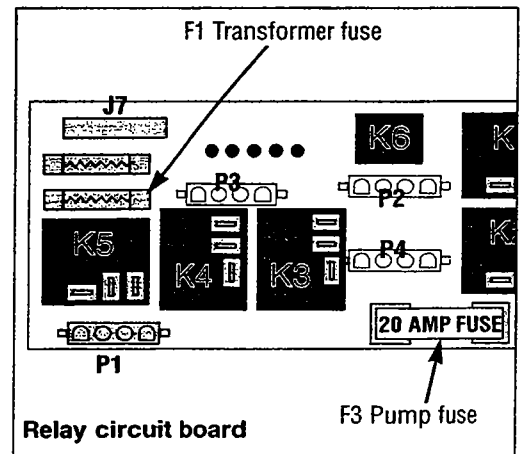
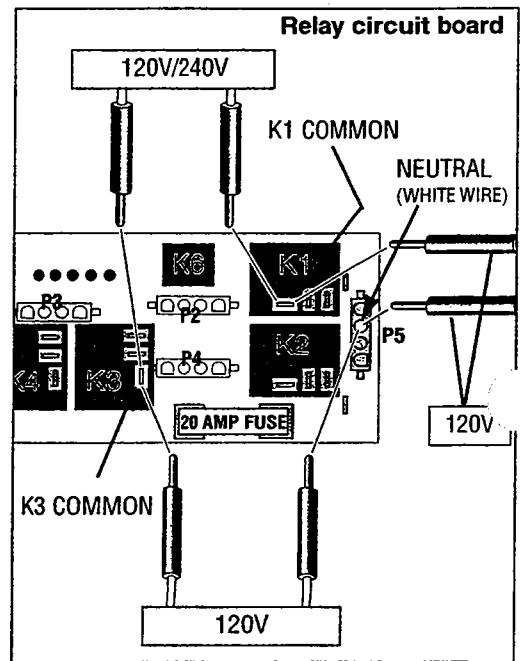

TROUBLESHOOTING SPECIFIC PROBLEMS

ERRATIC OPERATION:

Plug a Test Spa-Side Control into the spa-side receptacle J1 located on the Control circuit board:

- If the test spa-side control operates correctly, replace the spa-side control panel.
- If the test spa-side control does NOT correct the erratic operation, replace the Control circuit Board.

NOTE: In some cases of erratic operation, electrical interference can interfere with the operation of the spa control system. Typically, this interference is caused by "noisy" electronic devices, such as flourescent light ballast (used in ozone generators). In rare cases a noise suppressor or "across the line" filter may be required to resolve this type of problem. Contact the factory for more information.

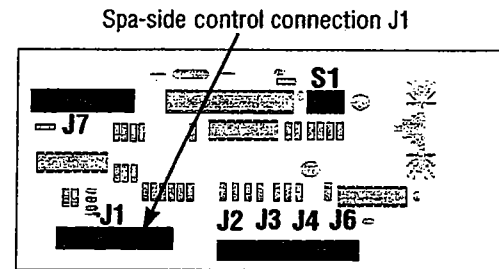

Control circuit board

ERRATIC OPERATION IN A COLD CLIMATE

In areas where freeze conditions may exist:

- The spa pump and heater will be activated automatically if the system detects a freeze condition (spa water temperature 40°F or lower). This often times is mis-diagnosed as "erratic operation". This is a normal control function and does not require service.

CONTROL TRIPS GFCI

Ground Fault Circuit Interrupter tripping is most often caused by a faulty heater. However, it may also be caused by one of the other components connected to the spa-side control system:

- Focus your search by identifying when the GFCI trips.
Example: A GFCI that only trips when the heater is operating, indicates a faulty heater.
- To identify which component is responsible for GFCI tripping, disconnect each component one at a time. Attempt to reset the GFCI, if the GFCI resets, the component that is disconnected is faulty.
- On 240V installations with a load neutral connection, verify that the GFCI breaker (if provided) has a load neutral connection and that the neutral wire from the spa is connected to the load neutral connection NOT the neutral buss bar.

TROUBLESHOOTING SPECIFIC PROBLEMS

PUMP HIGH SPEED (JETS) WILL NOT OPERATE

Press and release the JET touch pad (once for low speed, press again for high speed):

- ☐ The jet indicator light on the spa-side control and the jet Troubleshooting Indicator light on the Relay circuit board should be ON.
- ☐ If both of the indicator lights are ON the problem is not the spa-side control or the Control circuit board.

If the Spa-side control and Control circuit board check out:

- ☐ With the power OFF, use a OHM meter to check continuity of the 20 amp fuse (located on the Relay circuit board). If OPEN (infinite resistance) replace fuse.
- ☐ Remove the pump motor wiring cover and use a voltmeter to check for correct voltage (120 or 240 VAC) at the high speed wire termination (usually a red wire).
- ☐ If correct voltage is not present, check the wiring from the motor to the Relay circuit board P2 for loose or broken connections.
- ☐ If the connections are good, replace the Relay circuit board.

If correct voltage is present at the pump high speed wire termination:

- ☐ Replace the pump.

If the jet troubleshooting indicator light fails to illuminate:

- ☐ Check for a broken wire or a loose spa-side control connection at J1 on the Control circuit board.
- ☐ Check for a broken wire or a loose connection between the Control circuit board (J7) and the Relay circuit board (J7).

If the connections are good, and the jet indicator light on the spa-side control illuminates:

- ☐ With the jet indicator light ON, use a voltmeter to check power (120 or 240 VAC) at the jet relay K4 normally open output terminal.
- ☐ If the correct voltage is not present, replace the Relay circuit board.

If the jet indicator light on the spa-side control fails to illuminate:

- ☐ Disconnect the spa-side control and connect a test spa-side control to J1 on the Control circuit board.

- ☐ Press and release the JET touch pad two times. If the pump operates in high speed, and the jet indicator light on the spa-side control illuminates, replace the spa-side control.

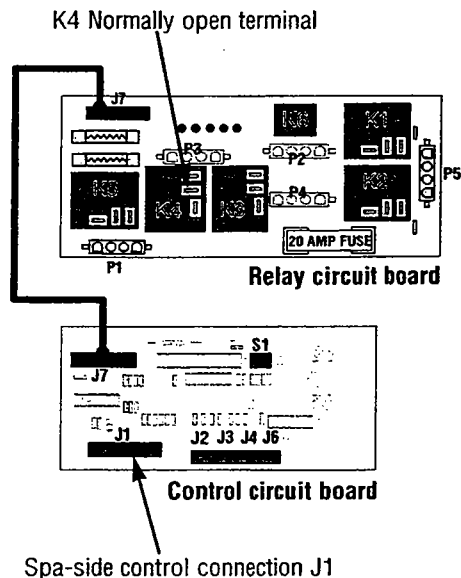
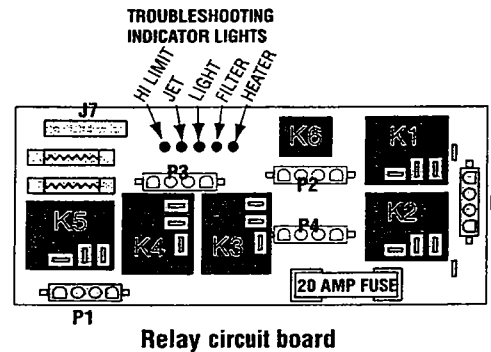
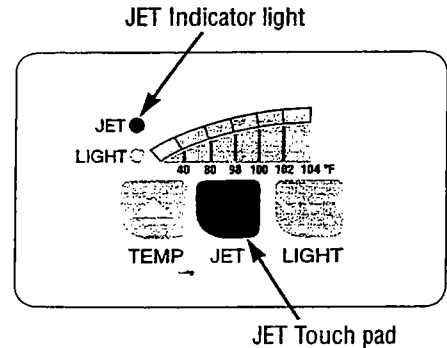

TROUBLESHOOTING SPECIFIC PROBLEMS

PUMP LOW SPEED (FILTRATION) WILL NOT OPERATE

Press and release JET touch pad:

- The filter troubleshooting indicator light on the relay circuit board should be ON.
- If the filter troubleshooting indicator light is ON, the problem is not the spa-side control or the Control circuit board.

If the Spa-side control and Control circuit board check out:

- Remove the pump motor wiring cover and use a voltmeter to check for correct voltage (120 or 240 VAC) at the low speed wire termination (usually a black wire).
- If correct voltage is not present, check the wiring from the motor to the Relay circuit board P2 (pump receptacle) for loose or broken connections.

If correct voltage is present at the pump low speed wire termination:

- Replace the pump.

If the filter troubleshooting Indicator Light fails to illuminate:

- Check for a loose spa-side control connection J1 on the Control circuit board.
- Check for a loose connection between the Control circuit board (J7) and the Relay circuit board (J7).

If the connections are good:

- Disconnect the spa-side control and connect a test spa-side control to J1 on the Control circuit board.
- Press and release the JET touch pad. If the pump operates in low speed, and the jet troubleshooting indicator light illuminates, replace the spa-side control.
- With the filter troubleshooting indicator light ON, use a voltmeter to check power (120 or 240 VAC) at the filter relay K5 normally open output terminal.
- If the correct voltage is not present, replace the Relay circuit board.

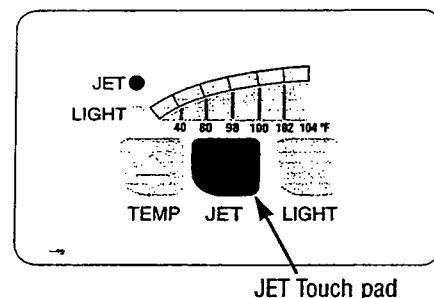

JET Touch pad

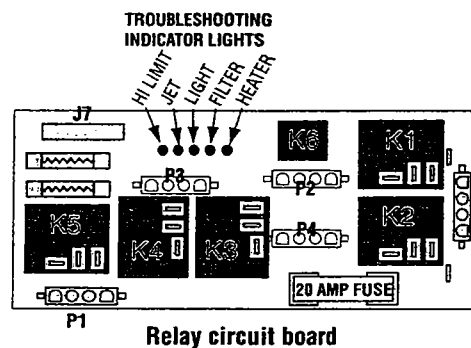

Relay circuit board

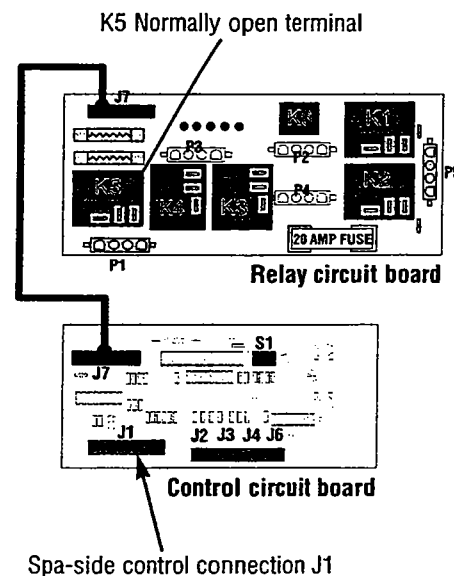

Spa-side control connection J1

TROUBLESHOOTING SPECIFIC PROBLEMS

FILTRATION CYCLE NOT WORKING PROPERLY

If the pump is operating in low speed but not filtering properly:

- The filter cycle is set at the factory to operate 4 hours each day.
- To increase the filtration cycle, reset the filter time switches S1 located on the Control circuit board.

FILTER CYCLE SETTINGS				
SW-1	SW-2	SW-3	SW-4	TIME
OFF	OFF	OFF		0
ON	OFF	OFF		4
OFF	ON	OFF		8
OFF	OFF	ON		12
ON	OFF	ON		16
OFF	ON	ON		20
ON	ON	ON		24

Note: SW-4 is not used.

Filter cycle switches (shown with factory preset of 4 hours filter time).

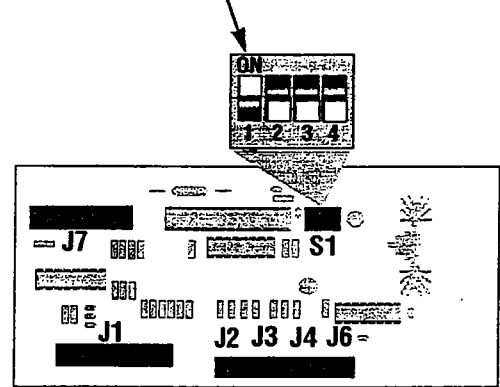

Control circuit board

OZONE GENERATOR OUTPUT WILL NOT OPERATE

With the pump operating in low speed:

- Use a voltmeter to check for correct voltage (120 or 240 VAC) at the Filter relay K5 normally open output terminal.
- If correct voltage is not present, check the wiring from the ozone unit to the Relay circuit board P3 (ozone receptacle) for loose or broken connections.
- Check for correct voltage at P3 (ozone receptacle) on the Relay circuit board.

If the connections are good and correct voltage is not present at K5:

- Replace the Relay circuit board.

NOTE: If the ozone generator is NOT the same voltage as the pump:

- If the ozone generator is 120V and the pump is 240V, a separate ozone relay, mounted off the Relay circuit board, will be used. Check the connection from this relay coil to the Relay circuit board as well as the power output from the relay output (normally open).

If the connections are good and correct voltage is present at the ozone generator receptacle P3:

- Replace the ozone generator.

K5 Normally open output terminal

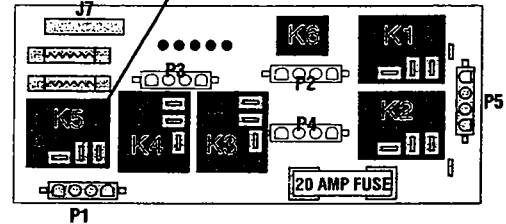

Relay circuit board

TROUBLESHOOTING SPECIFIC PROBLEMS

SPA LIGHT WILL NOT OPERATE

Press and release the LIGHT touch pad :

- The LIGHT indicator on the spa-side control and the light Troubleshooting Indicator light on the Relay circuit board should be ON.
- If both of the indicator lights are ON the problem is not the Spa-side control, Control circuit board or the Relay circuit board.

If the Spa-side control, Control circuit board and Relay circuit board check out:

- Remove the spa light and use a voltmeter to check for correct voltage (12VAC) at the light socket termination.
- If correct voltage is not present, check the wiring from the Relay circuit board P4 (light receptacle) for loose or broken connections.

If correct voltage is present at the light socket termination:

- Replace the bulb.

If the light troubleshooting indicator fails to illuminate:

- Check for a loose spa-side control connection J1 on the Control circuit board.
- Check for a loose connection between the Control circuit board (J7) and the Relay circuit board (J7).

If the connections are good, and the LIGHT indicator on the spa-side control illuminates:

- Connect a test Control circuit board, if the light works, replace the Control circuit board.
- If the light fails to work, replace the Relay circuit board.

If the Light indicator on the spa-side control fails to illuminate:

- Disconnect the spa-side control and connect a test spa-side control to J1 on the Control circuit board.
- Press and release the LIGHT touch pad. If the light operates , and the light indicator on the spa-side control illuminates, replace the spa-side control.

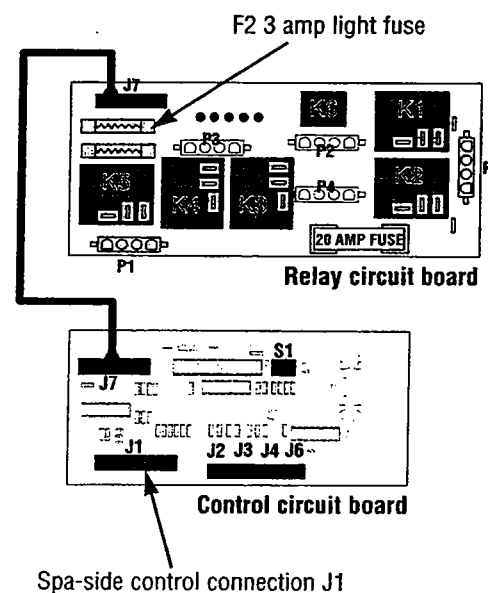
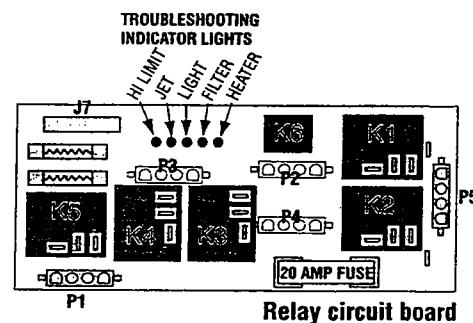
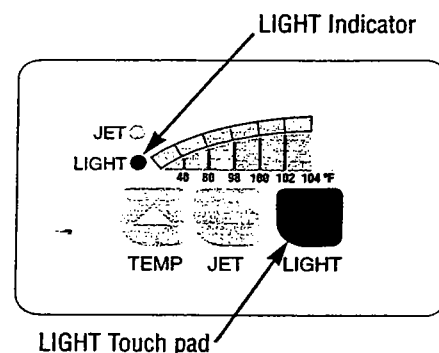

TROUBLESHOOTING SPECIFIC PROBLEMS

WATER TEMPERATURE TOO HOT OR SPA OVERHEATS

Check the location of the water temperature sensor:

- Make certain the sensor is fully inserted into the thermowell.
- The thermowell should be installed in the wall of the spa approximately 12 inches below the minimum water level.

Measure the water temperature with an accurate thermometer:

Note: The BL-45 is most accurate between 100 and 104°F. When measuring temperatures of 50°F or 60°F, the bargraph temperature display will indicate 40°F. Refer to TEMPERATURE SETTING page 4.

- If the temperature is several degrees or more higher than the temperature displayed on the spa-side control, check the temperature sensor. Refer to TEMPERATURE vs RESISTANCE table page 18 to evaluate the temperature sensor.
- If the temperature sensor checks out, replace the Control circuit board.

Turn the set temperature down to 40°F:

- Measure the voltage across the heater element terminals. If either 120V or 240V is present, replace the Relay circuit board.
- Check filtration program. A well insulated spa may overheat due to frictional pump heat. It may be necessary to reduce hours of filtration. Refer to FILTRATION CYCLE NOT WORKING PROPERLY page 13.

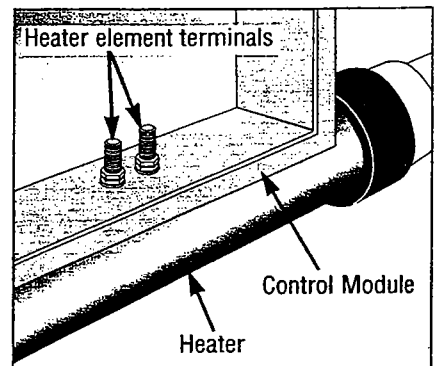
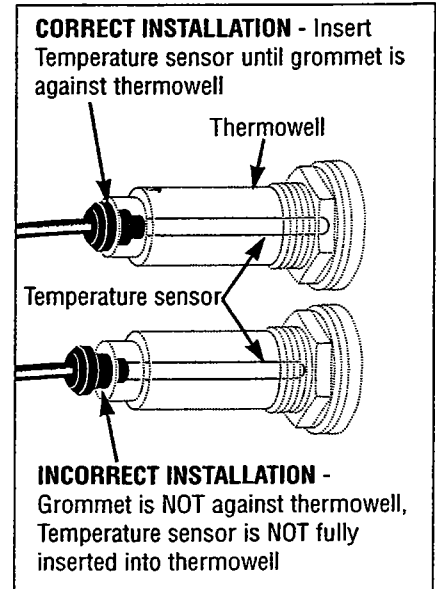

TROUBLESHOOTING SPECIFIC PROBLEMS

HEATER WILL NOT OPERATE

Note: If the spa is connected to 120VAC, the heater will not operate when the pump is operating in high speed (jets). Make sure the JETS are OFF on 120V systems when checking for a defective heater.

If an error code is displayed on the spa-side control panel:

- An error exists that is preventing the heater from operating. Refer to ERROR CODES page 7.

Press and hold the TEMP touch pad until the spa-side control displays 104°F:

- The heater Troubleshooting indicator Light on the Relay circuit board should illuminate after a few seconds.

With the heater Troubleshooting indicator light ON, measure voltage across the heater element terminals:

- If no voltage is present, replace the Relay circuit board.
- If either 120V or 240V is present, turn the power OFF and measure the resistance across the heater element terminals. A reading of approximately 10 ohms is normal. If the element resistance is infinite (open), replace the heater.

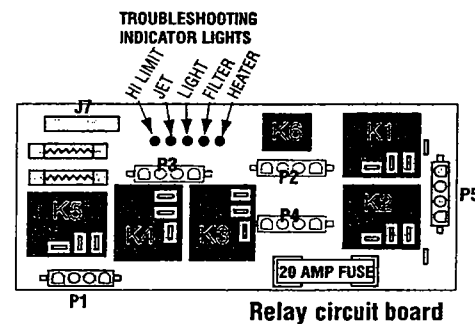
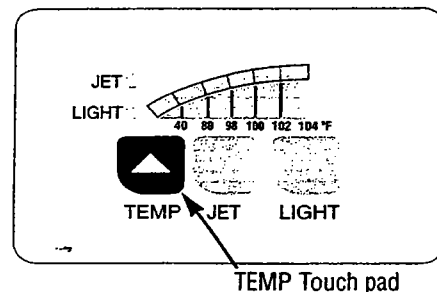

TROUBLESHOOTING SPECIFIC PROBLEMS

BARGRAPH TEMPERATURE DISPLAY INDICATES INCORRECT WATER TEMPERATURE

Check the location of the water temperature sensor:

- ❑ Make certain the sensor is fully inserted into the thermowell.
- ❑ The thermowell should be installed in the wall of the spa approximately 12 inches below the minimum water level.

Measure the water temperature with an accurate thermometer:

Note: The BL-45 is most accurate between 100 and 104°F. When measuring temperatures of 50°F or 60°F, the bargraph temperature display will indicate 40°F. Refer to TEMPERATURE SETTING page 4.

- ❑ If the temperature is several degrees or more higher than the temperature displayed on the spa-side control, check the temperature sensor. Refer to TEMPERATURE vs RESISTANCE table page 19 to evaluate the temperature sensor.
- ❑ If the temperature sensor checks out, replace the Control circuit board.

SPA WILL NOT MAINTAIN SET WATER TEMPERATURE

If the heater is operating but the spa water does not reach set temperature:

- ❑ The heat losses may be exceeding gains due to improper voltage being supplied to the spa.
- ❑ The spa must be covered with a thermal spa cover when not in use, or substantial heat loss will occur.

BARGRAPH TEMPERATURE DISPLAY DOES NOT WORK

If the bargraph temperature display fails to illuminate:

- ❑ Check for a loose connection at J1 on the Control circuit board.

If the connection is good:

- ❑ Disconnect the spa-side control and connect a test spa-side control to J1 on the Control circuit board.
- ❑ If the bargraph temperature display illuminates, replace the spa-side control.

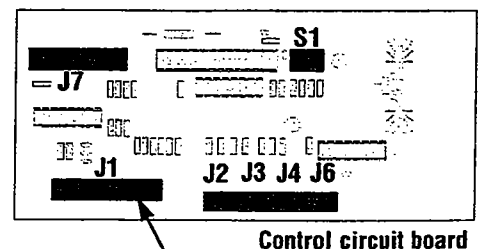
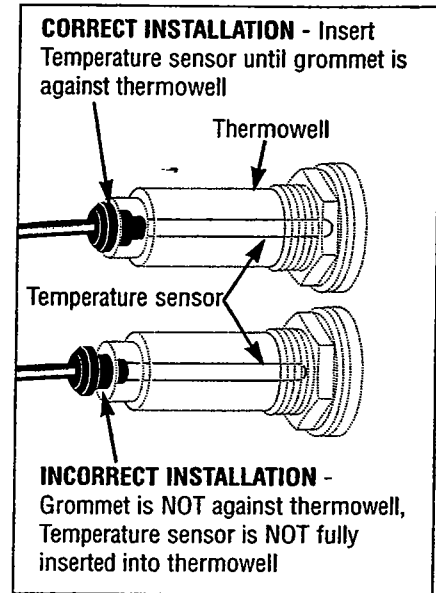

Spa-side control connection J1

TEMPERATURE vs RESISTANCE TABLE

TEMP. (degrees F)	THERM. KOHM	TEMP. (degrees F)	THERM. KOHM	TEMP (degrees F)	.THERM. KOHM
32	32.7	56	16.9	80	9.25
33	31.8	57	16.5	81	9.03
34	30.9	58	16.0	82	8.82
35	30.0	59	15.6	83	8.61
36	29.2	60	15.2	84	8.41
37	28.4	61	14.8	85	8.22
38	27.6	62	14.5	86	8.03
39	26.8	63	14.1	87	7.84
40	26.1	64	13.7	88	7.66
41	25.4	65	13.4	89	7.48
42	24.7	66	13.1	90	7.31
43	24.0	67	12.7	91	7.14
44	23.3	68	12.4	92	6.98
45	22.7	69	12.1	93	6.82
46	22.1	70	11.8	94	6.67
47	21.5	71	11.5	95	6.52
48	20.9	72	11.2	96	6.37
49	20.4	73	11.0	97	6.23
50	19.8	74	10.7	98	6.09
51	19.3	75	10.4	99	5.96
52	18.8	76	10.2	100	5.83
53	18.3	77	9.95	101	5.70
54	17.8	78	9.71	102	5.57
55	17.3	79	9.48	103	5.45
				104	5.33
				105	5.22

TEMPERATURE SENSOR AND HIGH LIMIT SENSOR CHECKOUT PROCEDURE

The temperature sensor and high limit sensor utilize a thermistor which changes resistance as a function of temperature. In order to troubleshoot the thermistor, you must know what the resistance should be at a given temperature.

Use a standard VOM (Volt/Ohm Meter) set to read R x 10,000:

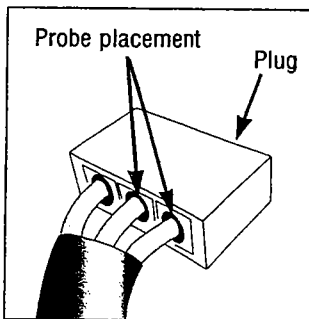

□ Disconnect the sensor from J2 (temperature sensor) or J3 (high limit sensor) on the Control circuit board. Attach a 3 pin base to the sensor plug to provide male contact points for resistance reading, or insert probe tips into the back of plug until contact is made.

- Using the VOM, record the resistance reading of the temperature sensor (by attaching the VOM probes to the leads that correspond with the wire connections on the temperature sensor).
- Use an accurate thermometer and check the spa water temperature. The acceptable range is 2°F above and 2°F below the actual spa water temperature. See the example below.
- Refer to the Temperature vs Resistance Table above and compare the spa water temperature to determine if the resistance readings are within the acceptable range.

- 2°F	92	6.98	↑ Acceptable resistance range ↓
	93	6.82	
	94	6.67	
Water temp.	95	6.52	
	96	6.37	
+ 2°F	97	6.23	
	98	6.09	



BRETT AQUALINE 5822 Research Drive • Huntington Beach, Ca. 92649